

Wireless World

ELECTRONICS, RADIO, TELEVISION

FEBRUARY 1963

Editor:

F. L. DEVEREUX, B.Sc.

Assistant Editor:

H. W. BARNARD

Editorial:

P. R. DARRINGTON

D. R. WILLIAMS

Drawing Office:

H. J. COOKE

Production:

D. R. BRAY

Advertisement Manager:

G. BENTON ROWELL

- 55 Editorial Comment
- 56 Controlled Rectifiers in Voltage-regulated Power Supplies
By F. Butler
- 62 World of Wireless
- 64 News from Industry
- 65 Personalities
- 67 H.F. Propagation in 1962 *By P. A. C. Morris*
- 70 Commonwealth Telephone Cable
- 71 Detecting Unlicensed Sets *By J. C. Fenning*
- 75 H.F. Predictions—February
- 76 Modulated Pulse A.F. Amplifiers *By D. R. Birt*
- 84 Oscillators: a Monistic Approach—2 *By T. Roddam*
- 88 Letters to the Editor
- 92 Manufacturers' Products
- 95 Transistor Amplifier Output Stages—2 *By O. Greiter*
- 99 What is an Electric Current? *By "Cathode Ray"*
- 102 February Meetings
- 104 Unbiased *By "Free Grid"*

VOLUME 69 No. 2

PRICE: 2s 6d.

FIFTY-SECOND YEAR
OF PUBLICATION

Managing Director: W. E. Miller, M.A., M.Brit.I.R.E.

Iliffe Electrical Publications Ltd., Dorset House, Stamford Street, London,
S.E.1

Please address to Editor, Advertisement Manager, or Publisher as appropriate

© Iliffe Electrical Publications Ltd., 1963. Permission in writing from the Editor must first be obtained before letter-press or illustrations are reproduced from this journal. Brief abstracts or comments are allowed provided acknowledgement to the journal is given.

PUBLISHED MONTHLY (4th Monday of preceding month). *Telephone:* Waterloo 3333 (70 lines). *Telegrams:* "Ethaworld, London, Telex." *Cables:* "Ethaworld, London, S.E.1." *Annual Subscriptions: Home and Overseas, £2 0s. 0d. Canada and U.S.A. \$5.50.* Second-class mail privileges authorized at New York, N.Y. *BRANCH OFFICES: BIRMINGHAM:* King Edward House, New Street, 2. *Telephone:* Midland 7191. *COVENTRY:* 8-10, Corporation Street. *Telephone:* Coventry 25210. *GLASGOW:* 62, Buchanan Street, C.1. *Telephone:* Central 1265-6. *MANCHESTER:* 260, Deansgate, 3. *Telephone:* Blackfriars 4412. *NEW YORK OFFICE:* U.S.A.: 111, Broadway, 6. *Telephone:* Digby 9-1197.

PL500 LINE OUTPUT PENTODE FOR DUAL STANDARD RECEIVERS

It is important in dual-standard television receivers to ensure that the performance of the line timebase does not deteriorate when the receiver is switched from one line standard to the other. Most of the functions of the line timebase are critical in application and such changes in performance would therefore be noticed by the viewer. Thus consistency in performance must be achieved despite the fact that the energy requirements for 625-line operation are roughly half as great again as those of 405-line operation.

In many new dual-standard receivers, the task of ensuring comparable performance has been simplified by utilising the new Mullard line output pentode, type PL500. This new valve has improved ratings compared with valves previously recommended for 405-line operation. In particular, an exceptionally high ratio of anode current to screen-grid current is achieved by an entirely new form of anode—the

'cavitrapp' anode—which is illustrated in the diagram. With this construction, secondary-emission electrons from the anode—

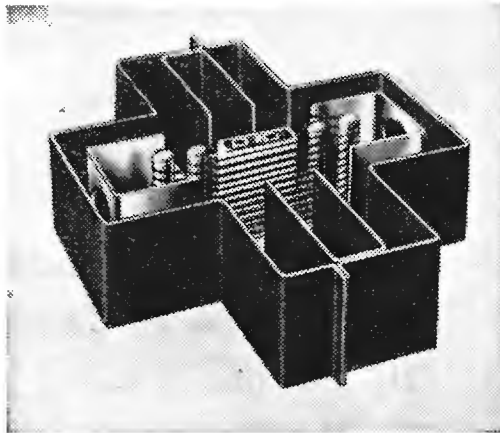

which contribute greatly to the screen-grid current—are recaptured by the partitions of the cavitrapp anode. Because of this improved current ratio, the PL500 is capable of delivering the greater deflection power which is useful for 625-line scanning, and helps to prevent any significant change in performance between the two line standards.

AW59-91 23-INCH SHORT-NECK PICTURE TUBE

The new Mullard picture tube, type AW59-91, has a rectangular screen with a 23-inch diagonal and deflection angle of 110°. The flatness of the screen offers a wide viewing angle and freedom from distortion when viewed obliquely. Electrostatic focusing is used and the focusing lens is of the unipotential type, which prevents deflection defocusing and thus ensures good spot quality over the whole picture area. An ion-trap is unnecessary with the AW59-91, so that interaction between the ion-trap magnet and the deflection coils is absent, and there is a consequent further improvement in spot quality.

WHAT'S NEW IN THE NEW SETS

These articles describe the latest Mullard developments for entertainment equipment

The design of the electrode structure of the gun of the AW59-91 is such that a very short gun has been achieved. In addition to this, the sealing pip at the base of the gun is very small, so that the total length of the tube neck is only 110mm. The overall reduction in the length of the AW59-91 resulting from the short-neck construction has made possible even greater reductions in the depth of television cabinets, leading to the more slender appearance of present-day sets. The electrical and physical advantages of the short-neck construction make the AW59-91 an important advance in picture tube design.

AF118 Alloy-Diffused Transistor for Video Output Stages

In present-day transistor television receivers, the requirements of the video output amplifier are being fulfilled by the Mullard AF118 alloy-diffused transistor.

The feedback capacitance of a transistor forms the major limitation to its application as a wideband amplifier. At high frequencies this capacitance greatly reduces the input impedance of the transistor, which thus shunts the input circuit and attenuates the signal. The limitation is accentuated when high voltage gains are required and is therefore particularly troublesome in video output stages where an output of some 60V must be available to drive the picture tube. In the AF118, the feedback capacitance is only 1.8pF, and this very low value has been made possible by the alloy-diffusion technique of transistor production.

The output signal obtainable with a transistor is limited by the collector voltage and dissipation ratings of the transistor. The alloy-diffusion technique gives a high collector breakdown voltage, and the rating of the AF118 is such that the available video drive voltage at full bandwidth is greater than 65V. The thermal resistance of the transistor and envelope—which sets the collector dissipation rating—has been reduced to such an extent that a maximum dissipation of 375mW is permissible with the AF118.

Good high-voltage and high-power properties are thus features of the AF118. With these and the excellent high-frequency performance that characterises Mullard alloy-diffused transistors, the AF118 video output transistor is therefore particularly suited to the difficult task of bridging the gap between the semiconductor devices and the picture tube in transistor television receivers.

MVE/CA1025

Research in Radio and Electronics

THE proportion of income which can be earmarked for research is limited in the commercial field by the need to keep prices competitive, and on a national basis by the numerous other demands made upon the treasury, even in the vital sector of defence. In the radio and electronics industry it is possible only to give estimates, but the general consensus of opinion seems to be that about 10% of income is earmarked for research and development, but that only 1% or at the most 1½% is spent on pure research. Yet another estimate puts the number of research workers per 1,000 employees in the radio and electronics industry in the U.K. at 5, whereas in the U.S.A. it is 13. Clearly there is need for expansion.

At the annual dinner of the Radio and Electronics Industry in November 1961, Earl Mountbatten, President of the Brit. I.R.E., drew attention to the situation and called for a "combined operation" by the two industry Councils. In May last year he also asked the Research Committee of Brit. I.R.E., under the chairmanship of Mr. L. H. Bedford, to survey the present position and to make recommendations. After a period of fact finding a Symposium was held in January this year and a final report is due for publication next month.

Opening speakers at the Symposium (Committee members expressing personal views) were Prof. D. G. Tucker (Birmingham Univ.), Dr. H. Motz (Oxford Univ.), Prof. E. E. Zepler (Southampton Univ.), Dr. Denis Taylor (Plessey) and Mr. I. Maddock (A.W.R.E.) who discussed the material environment and intellectual resources for pure research from the standpoints of the universities, of industry and of Government.

It was generally agreed that adequate funds were available from Government grants and from industry for objective research projects in universities, but that the paper work involved in making applications and writing progress reports took a disproportionate amount of time and energy. Research was not held up for lack of apparatus and, as Prof. Tucker pointed out, over-equipment could exercise a retarding influence just as much as under-equipment. (We remember Rutherford's dictum: "As we are short of equipment we must think.") Most speakers expressed the view that the gravest shortage at the present time was in the number of available workers with the intellect and competence necessary for front-line research. Unless we found and nurtured more talent any expansion must inevitably result in dilution. More could be done to stimulate interest in radio and electronics among

schoolboys (and girls) and in the universities the examples of Southampton, Bangor and Nottingham should be followed in paying something more than lip service to these subjects, which had long since been recognized as disciplines in their own right. Although not referred to in the Symposium we think it might be mentioned at this point that an excellent scheme for stimulating research in the sixth forms of schools by help and advice from Fellows has been initiated by the Royal Society. A list of physical subjects undertaken in this scheme shows a token inclusion of radio and electronics which might well be extended. One fundamental difference between research in industry and in educational establishments was underlined by Prof. Tucker, namely, that the routine and spadework inseparable from objective research in industry must be kept to a minimum in universities where the choice of programmes should be governed by their teaching content. Universities must not be regarded by industry and Government merely as a means of getting research done.

A good point was made by one speaker who thought that the choice of environment for research should be governed by the question of pace. The earlier stages of a research might be good for teaching, but when the point of "breakthrough" had been reached and the matter had achieved the status of a project, it might well be transferred elsewhere.

Contact with Government establishments was too often hamstrung by "security," but Prof. Tucker thought that Government scientists ought from time to time to be seconded to universities where the more rigorous treatment of research might have a beneficial influence. Mr. Maddock thought that there was unnecessary diffidence in approaching "establishments behind the iron fence" and that there might also be some laziness inside which delayed the declassification of much useful information.

In drawing the discussion to a close the chairman said that the Symposium, in spite of some conflicting evidence on matters of detail, had supported the Committee's opinion that the most effective method of strengthening research was to start first with the universities—by bulk support rather than by subsidizing individual projects. This would fertilize the whole operation, not only by sending out well-trained men into industry but by ensuring that new ideas and discoveries were more rapidly and widely disseminated.

This seems to us to be an eminently sound policy and we shall look forward to reading the Committee's final report.

Controlled Rectifiers in Voltage-regulated Power Supplies

By F. BUTLER, O.B.E., B.Sc., M.I.E.E., M.Brit.I.R.E.

A SILICON controlled rectifier is a 3-terminal solid-state device having anode, cathode and gate electrodes. When connected in series with a d.c. source and a load resistance it blocks current in the direction which makes the anode negative. If the polarity of the supply is reversed so as to make the anode positive the device remains non-conducting unless the gate electrode is simultaneously driven positive to an extent sufficient to produce a certain critical gate current. When this level of current is exceeded the SCR is triggered into conduction and passes current which is limited by the applied voltage, the circuit resistance and the small voltage drop across the rectifier. Once conduction has been started the gate electrode ceases to exercise control and current cut-off is only possible by switching, reversing the anode voltage or by introducing so much resistance into the circuit that the current drops to a value below the holding current, defined as that current below which the SCR reverts to the forward blocking condition.

Controlled rectifiers are rated in terms of the peak forward and peak reverse blocking voltages they can safely withstand and in terms of the peak pulse and mean current they can pass in the conducting mode. Gate drive power requirements are very small and a few milliwatts is sufficient to turn on anode currents of hundreds of amperes. As in all semiconductor devices, some of the properties of SCRs are temperature dependent, notably the forward and reverse leakage currents and the gate drive requirements. The use of silicon material makes it possible to run up to temperatures around 100°C without serious derating.

If used in series with an a.c. source and a resistance load, a controlled rectifier behaves exactly like a silicon diode so long as the gate is held sufficiently positive. If the gate trigger voltage is delayed in time with respect to the start of the positive half-cycle of the anode voltage wave, conduction will also be delayed and, with a fixed load, the mean value of the rectified current will be reduced. This gives a clue to the way in which controlled rectifiers may be used to develop a constant voltage across a variable load. In principle, one needs to devise some automatic means for advancing or retarding the gate trigger voltage in response to variations of load current. There are many possible ways of doing this, some of them extremely complicated.

Gate Trigger Arrangements—Fig. 1 shows some elementary circuits employing controlled rectifiers. The uppermost diagram shows a positive half sine

wave voltage applied to an SCR through the load resistance R_L . The gate electrode is supplied through a resistance R_G , large enough to limit the gate current to a safe maximum value. The output voltage across the load is not an exact replica of the input because the SCR does not fire until the gate current reaches its critical value. A small part of the output wave is thus missing but it represents only a few electrical degrees of the entire cycle. The effect is insignificant.

The centre diagram shows how the gate firing voltage may be delayed by charging a capacitor C through the gate resistance R_G . The SCR is fired later in the cycle and the load voltage waveform is only a portion of a half sine wave. Clearly, this delayed firing reduces the mean value of the load current. Simple time-constant theory cannot be employed to deduce the charging rate of capacitor C because the SCR gate circuit has a finite and non-linear input impedance which loads the capacitor, slows down the charge rate and reduces the peak voltage developed across it. This state of affairs can be improved somewhat by connecting a resistance of a few hundred ohms in series with the SCR gate electrode. Even if C is omitted from the circuit it is still possible to delay the firing of the SCR merely by increasing the resistance in the gate circuit so that sufficient gate current for triggering is reached only near the crest of the half sine wave input voltage. Experience shows that the gate drive voltage required for triggering depends to some extent on the magnitude of the applied anode voltage and it is possible to take advantage of this effect in some practical circuits.

The time delay circuits so far discussed are only usable with a positive input voltage. With an a.c. source the arrangement in the bottom diagram may be employed. As before, neglecting the gate circuit input impedance, the time delay is set by the product of C and R_G . The diode $D1$ serves to discharge C during that half-cycle of the input voltage which makes the SCR anode negative. This resets C in readiness for the next charging cycle. Controlled rectifiers are liable to be damaged if a large negative voltage is applied to the gate electrode. The diode $D2$ removes this possibility. C and hence $D1$ are not essential to the delay action and they may be removed. If this is done, an increase in R_G will delay triggering but this delay cannot possibly exceed one quarter or 90 degrees of a complete cycle. At this point the anode voltage and gate current both reach their maximum values and afterwards fall rapidly. If triggering has not been

accomplished at the peak of the cycle it is unlikely to occur later. Introduction of C serves to give a little extra delay. Another possibility is to feed R_G from a d.c. source instead of the a.c. supply. This allows later firing with the capacitor-delay arrangement since the peak voltage may be reached quite late in the cycle. There is no trouble due to the falling voltage after the 90 degree point in the cycle as there is in the a.c. case. A suitable d.c. source is readily obtained by half-wave rectification of the input a.c., followed by a simple filter which may consist of a large electrolytic capacitor.

It is not difficult to double up the last circuit in Fig. 1 to give full-wave rectification and to allow for voltage control by variation of the gate circuit resistance R_G . It then remains to provide filter circuits to give a suitably smoothed d.c. output and to devise an automatic regulator which will vary the capacitor charging rate in proportion to the load current, advance the SCR firing and thus preserve a constant output voltage. For example, a transistor might conceivably be used instead of, or in addition to R_G . A control signal applied to its base could

be arranged to compensate for a falling output voltage characteristic.

Experimental Circuits Using SCRs

A number of d.c. power supply units using SCRs and operating from a.c. mains have been built and tested. Some give a manually variable d.c. output over a voltage range of about 3 to 1 without switching, or over any desired range if the supply transformer has a tapped secondary winding. Others are arranged to give a regulated output, at a preset voltage, over a wide load-current range. If desired, the characteristic can be adjusted so that the output voltage rises slightly as the load current is increased. In some the response time is quite rapid, limited only by the capacitance in the filter circuit. In others the response is more sluggish but there are compensating advantages to offset this defect. The aim has been to concentrate on fundamental principles rather than to produce a design to meet one specific requirement. So many variants have been produced that it is out of the question to describe all of them.

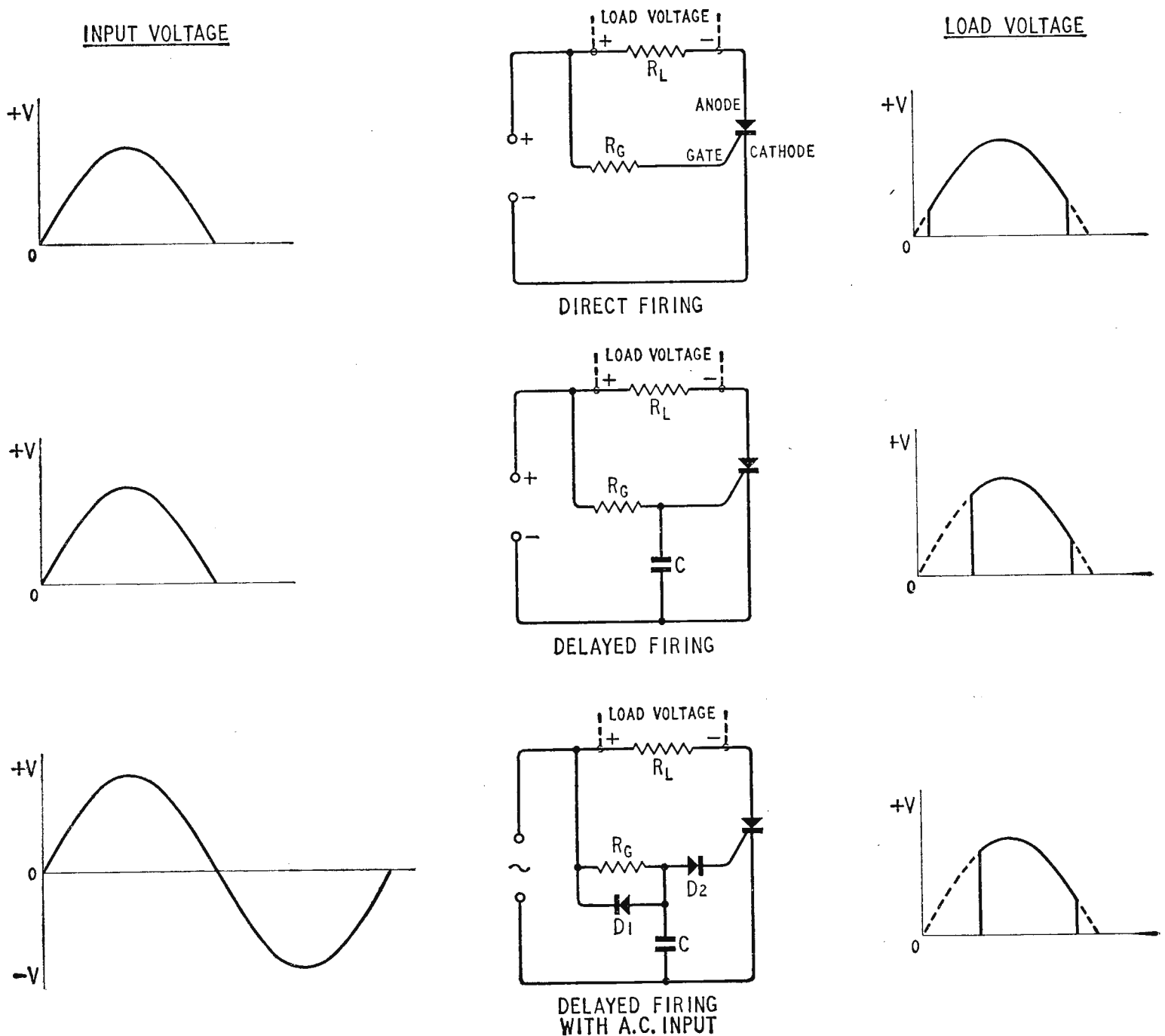

Fig. 1. Basic firing circuits for use with controlled rectifiers.

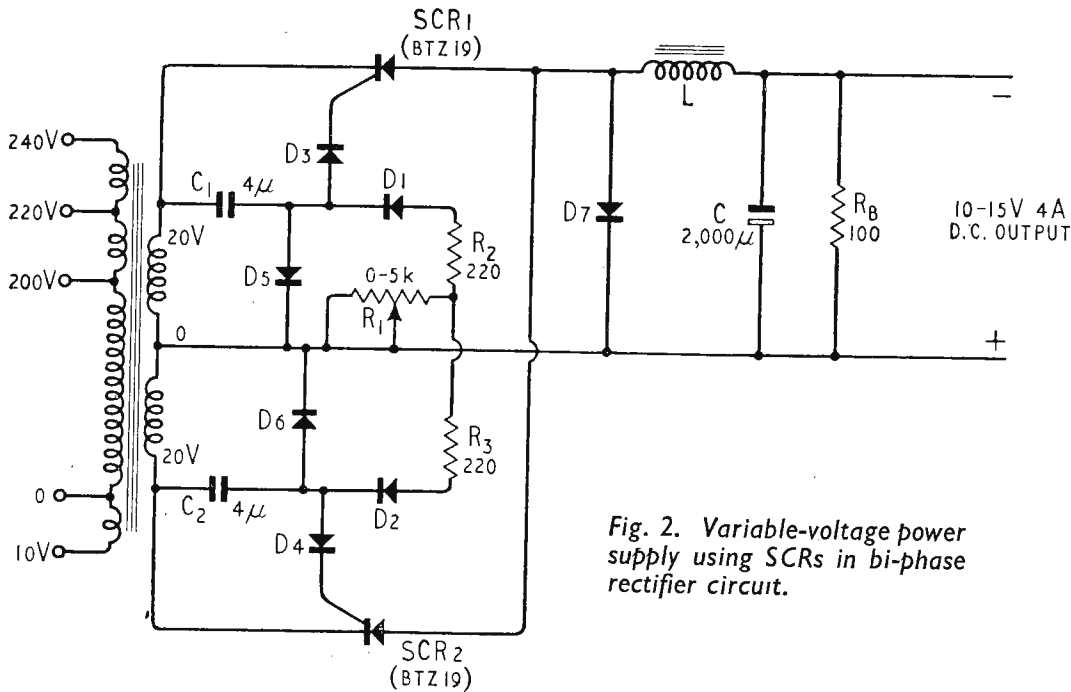

Fig. 2. Variable-voltage power supply using SCRs in bi-phase rectifier circuit.

for the next charging sequence. Later, C_2 is similarly discharged through D_6 . The diodes D_3 and D_4 prevent the SCR gates from being driven negative, and D_1 and D_2 decouple C_1 and C_2 from each other. All these diodes are inexpensive low-power silicon types rated at 500mA with a peak inverse voltage of 200 or more depending on the d.c. output voltage.

The diode D_7 serves to maintain load current in the inductive circuit while both SCRs are in the blocked condition. It must be able to carry a peak current at least equal to the full load current and should be rated to withstand a peak inverse voltage about three times the d.c.

Only a few will be selected and, in order to reduce the number of drawings, the more complex circuits will be given and the simpler ones derived from them by listing the parts which can be omitted. This is a reversal of the normal procedure but the argument will not be difficult to follow.

Fig. 2 shows one of the first arrangements to be used. The controlled rectifiers SCR1 and SCR2 operate in a bi-phase circuit with a power transformer having a centre-tapped secondary winding. The rectified output is smoothed by a choke-input filter LC. The series-connected resistances R_1 and R_2 or R_3 correspond to R_G in the previous discussion. When the voltage on C_1 reaches a critical level, SCR₁ fires and conducts load current until near the end of that half-cycle. As soon as the anode current falls below the holding current, SCR1 cuts off. On the next half-cycle, SCR2 is similarly triggered, after C_2 has become charged through R_1 , R_3 and D_2 . Meanwhile, C_1 has been discharged through D_5 ready

output voltage. The inductor L is a swinging choke. For use on a 50 c/s supply the minimum value of the inductance in millihenries should be about the same as the load resistance in ohms. An inductance lower than this tends to cause the filter to behave as if it had a capacitor input and the voltage regulation is impaired. A properly designed choke-input filter gives good voltage regulation without special control and also makes the most efficient use of rectifier and transformer ratings. Rectifier peak currents are much lower than with a capacitor-input filter.

By manual adjustment of R_1 , the output voltage may be varied over the range 10-15 volts or more. At the lowest output, it may be found that one or other of the SCRs fails to trigger, or fires erratically. The range of voltage control may be increased by varying R_2 or R_3 , each shown as 220 ohms, until symmetrical firing is achieved. When only a moderate range of voltage control is satisfactory, some drastic simplifications can be made. C_1 , C_2 , D_1 , D_2 ,

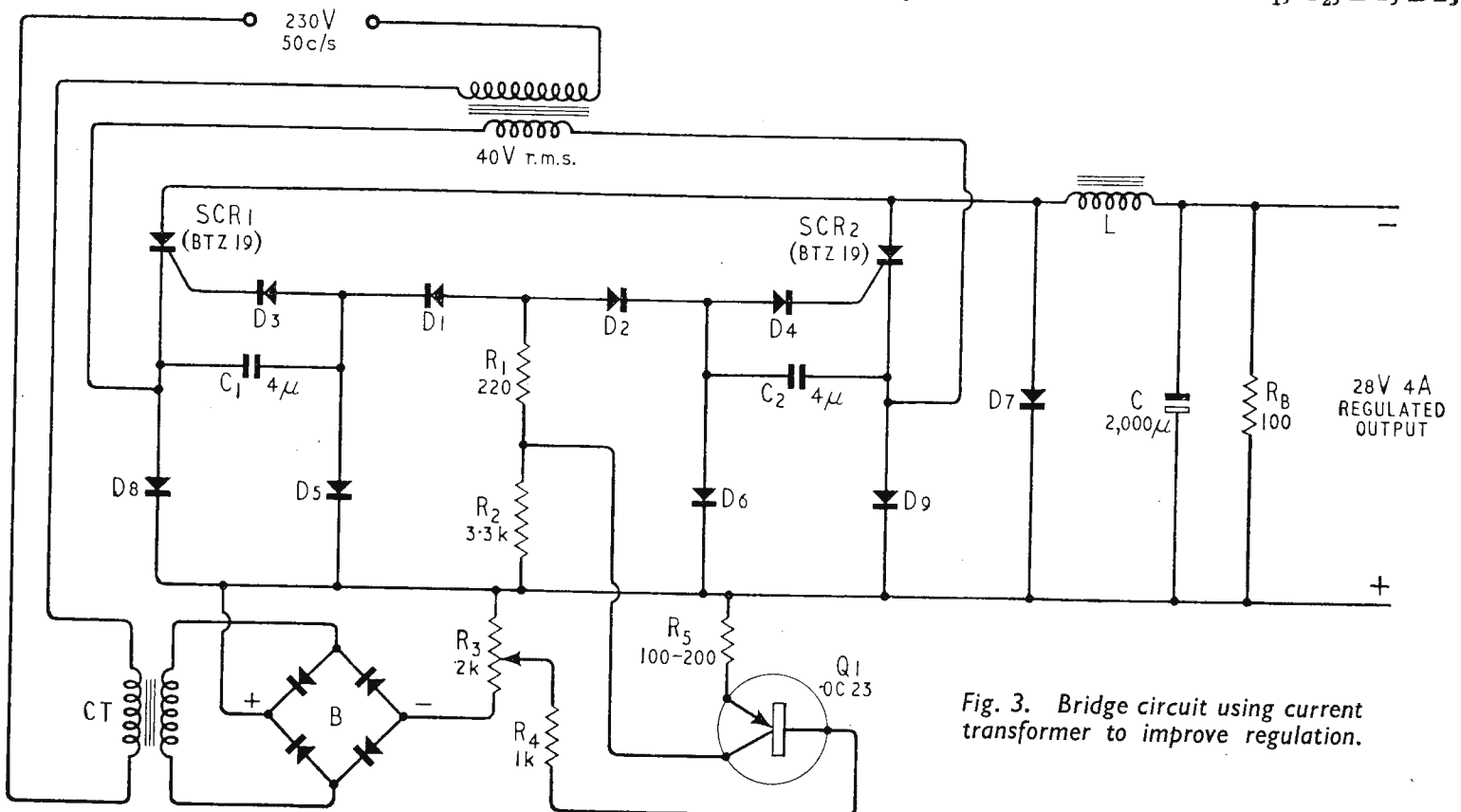

Fig. 3. Bridge circuit using current transformer to improve regulation.

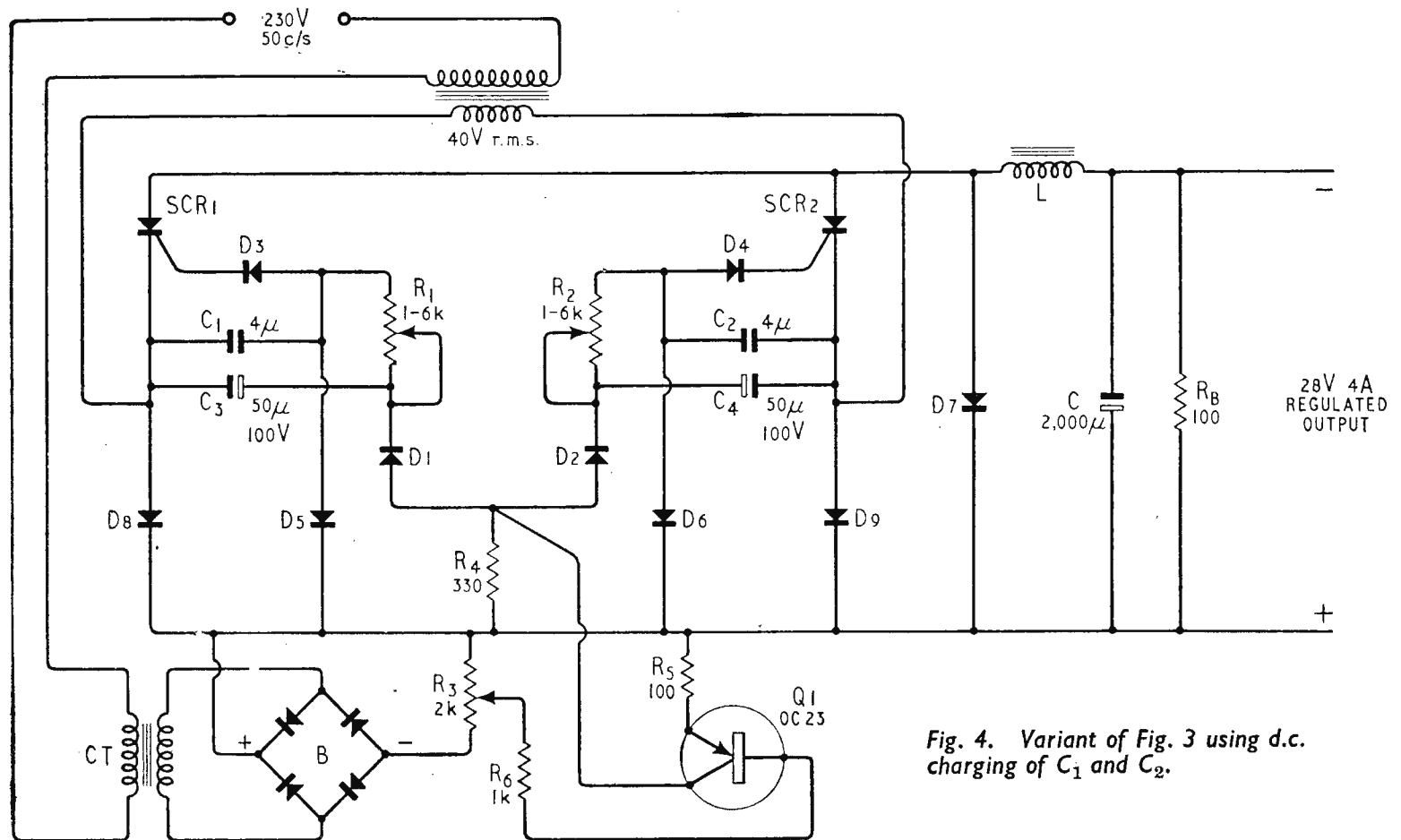

Fig. 4. Variant of Fig. 3 using d.c. charging of C_1 and C_2 .

D5 and D6 may be removed, readjusting R_2 or R_3 to preserve symmetrical triggering of the SCRs. If sufficient care is taken it ought to be possible to control the output voltage over a 2 : 1 range.

The ballast resistance R_B should be small enough to ensure that the SCR anode current does not fall below the holding current over a significant part of the conducting cycle. It is possible that low-voltage operation, with C in use, might be improved by removing R_2 and R_3 from their present positions and inserting them in series with D3 and D4. These resistances must not be made so small that the rated maximum gate current of the SCRs is exceeded. On the other hand, too large a value will cause undesired delay in firing the controlled rectifiers, resulting in a reduced output voltage. In cases where long-delayed firing of the SCRs is essential it is necessary to increase the value to C_1 and C_2 , shown as $4\mu\text{F}$, to a much larger figure. If electrolytics are used they must be connected in back-to-back pairs to make them non-polar.

The next development is shown in Fig. 3. Here, two extra power-diodes D8 and D9 have been added to work in conjunction with SCR1 and SCR2 as a bridge rectifier. This avoids the necessity for a centre-tapped power transformer and makes better use of the transformer materials. The circuit also has provision for voltage regulation of the output in the face of load current changes. This is achieved by using a transistor Q1 in parallel with R_2 in the SCR gate circuits. If Q1 is forward biased into conduction its collector current will add to the normal gate-circuit current and cause earlier firing of the SCRs. If the base bias or Q1 can be made to increase with an increase in load current this can compensate for the voltage drop which normally occurs. Proportional bias is derived from a current transformer CT associated with the bridge rectifier B. The primary of CT carries the a.c. line current to the main unit.

The line current is almost proportional to the load current and, in consequence, Q1 is forward biased to an increasing extent as the load demand increases. The setting of the slider of R_3 determines the actual bias current and it is possible to obtain a flat output voltage characteristic at one particular setting. At a higher setting a rising output voltage will result from an increase of load current. This arrangement will not compensate for mains voltage changes but in many applications this is of no consequence.

The desired output voltage can be preset by adjustment of R_2 or by varying C_1 and C_2 , and good regulation can be achieved at any setting. Some readjustment of R_3 may also be necessary. In Fig. 3, no provision is shown for ensuring regular firing of the SCRs at low output levels. The simplest way of achieving this is to duplicate R_1 , feeding D1 through one half and D2 through the other.

If a very wide range of variation of d.c. output voltage is not required, the circuit may be much simplified; C_1 , C_2 , D1, D2, D5 and D6 may all be removed with scarcely any effect on the performance over the upper 25 per cent of the full output voltage. The circuit becomes simpler still if a modest range of manually adjustable output voltage is satisfactory. In this case CT, Q1 and the bridge rectifier B can be removed, leaving only D3, D4, R_1 and R_2 in the SCR gate circuit. Voltage control is effected by variation of R_2 . The regulation remains fairly good.

The current transformer CT should develop about 10 volts across a $2\text{k}\Omega$ load on its secondary side when full load line current flows in the low-resistance primary. A small filament transformer 230V to 6.3V or a loudspeaker transformer matching a pentode or tetrode amplifier to a 3Ω load will serve the purpose. Good insulation between the windings is of course essential.

The most elaborate circuit to be discussed is that shown in Fig. 4. One feature is that the SCR gate

electrodes are supplied from a d.c. source obtained by half-wave rectification of an a.c. supply. This system allows for an increase of the range of d.c. output voltage over which control and regulation can be achieved. If R_4 is assumed to be short-circuited, diode D1 acts as a half-wave rectifier and develops a smoothed direct voltage across the large electrolytic reservoir capacitance C_3 . Diode D2 works similarly in conjunction with C_4 . The delay in firing SCR1 is produced by the component C_1 and R_1 and that in firing SCR2 by C_2 and R_2 . Control of the delay is by variation of R_1 and R_2 which take the form of a twin-gang 0-5k Ω potentiometer. Fixed resistances, each 1k Ω , are used in series with R_1 and R_2 to limit the SCR gate current to a safe maximum value and to equalize the trigger sensitivity of the two controlled rectifiers. If desired, these equalizing resistors may be connected directly in the gate circuits in series with D3 and D4, but the main resistances R_1 and R_2 must remain in the position shown. R_4 and Q1 together act like a variable resistance in series with the rectifier diodes D1 and D2. Variation of the base bias on Q1 causes a change in this resistance and affects the level of the rectified voltage appearing across C_3 and C_4 . In turn, this alters the charging rate of capacitors C_1

and C_2 and advances or retards the firing of the SCRs. Automatic voltage control is again provided by the current transformer and its associated components.

The resistances R_2 in Fig. 3 and R_4 in Fig. 4 are essential components. Without them the systems would not be self-starting if it so happened that the slider of R_3 was set in its zero position. This would keep Q1 cut off and no gate current would be available to fire the SCRs. The resistances also exercise a stabilizing effect on the output voltage. In effect, the current transformer provides a positive feedback loop in which excessive gain would put so much forward bias on Q1 that it would saturate and drive the SCRs to full output. R_2 and R_4 dilute this feedback. The small resistance R_5 in the emitter lead of Q1 (Figs. 3 and 4), provides some negative feedback and tends to linearize the gain.

The circuit of Fig. 4 is not only more complex than that of Fig. 3 but it is more sluggish in its response to sudden load changes. Against this, it gives a wider range of voltage variation over which close regulation is possible at any preset level.

Voltage Waveforms:—Fig. 5 shows some observed voltage waveforms at various points in Fig. 3. The

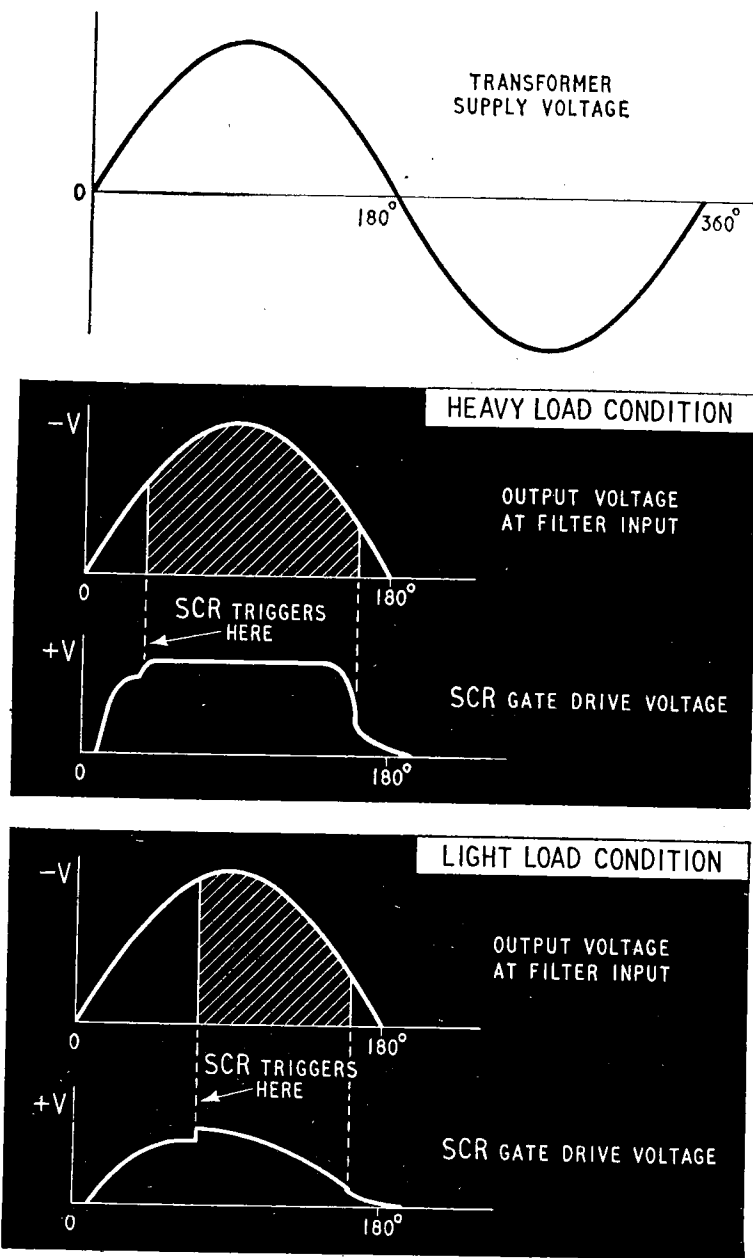

Fig. 5. Waveforms at various points in circuit of Fig. 3.

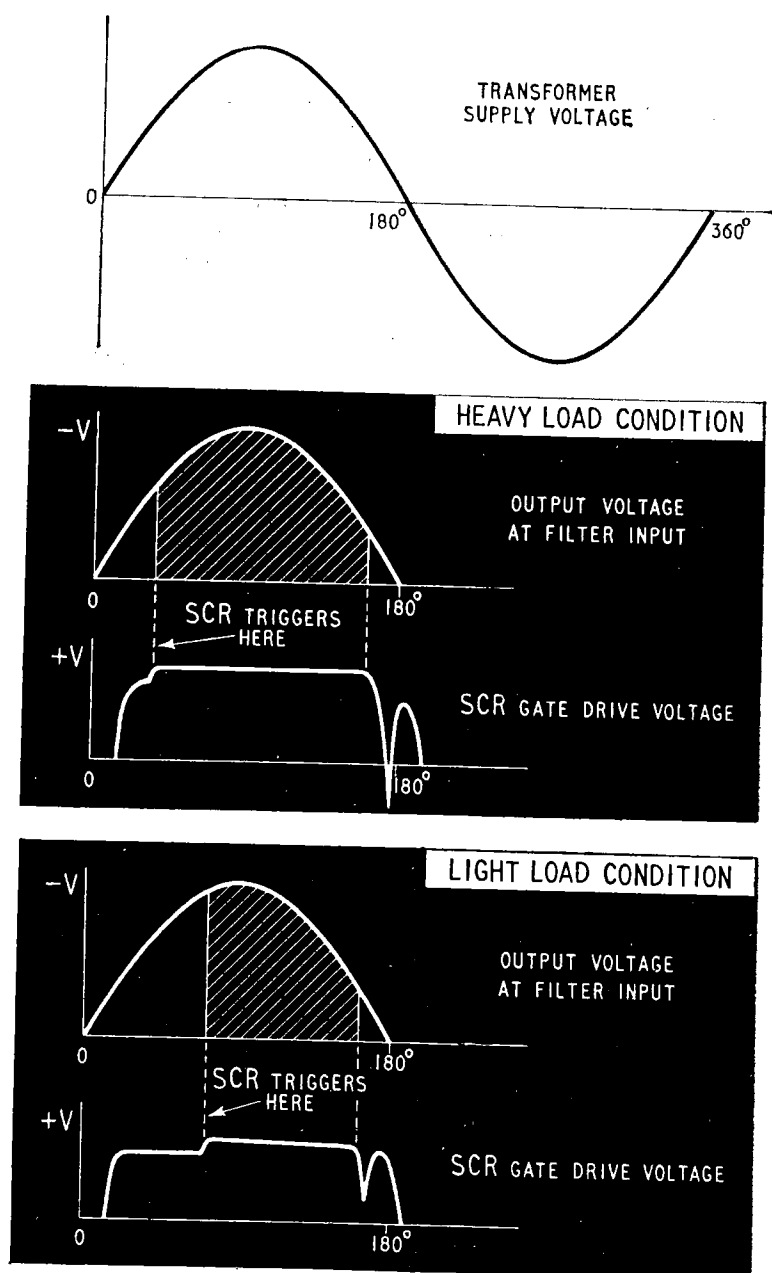

Fig. 6. Waveforms at various points in Fig. 4.

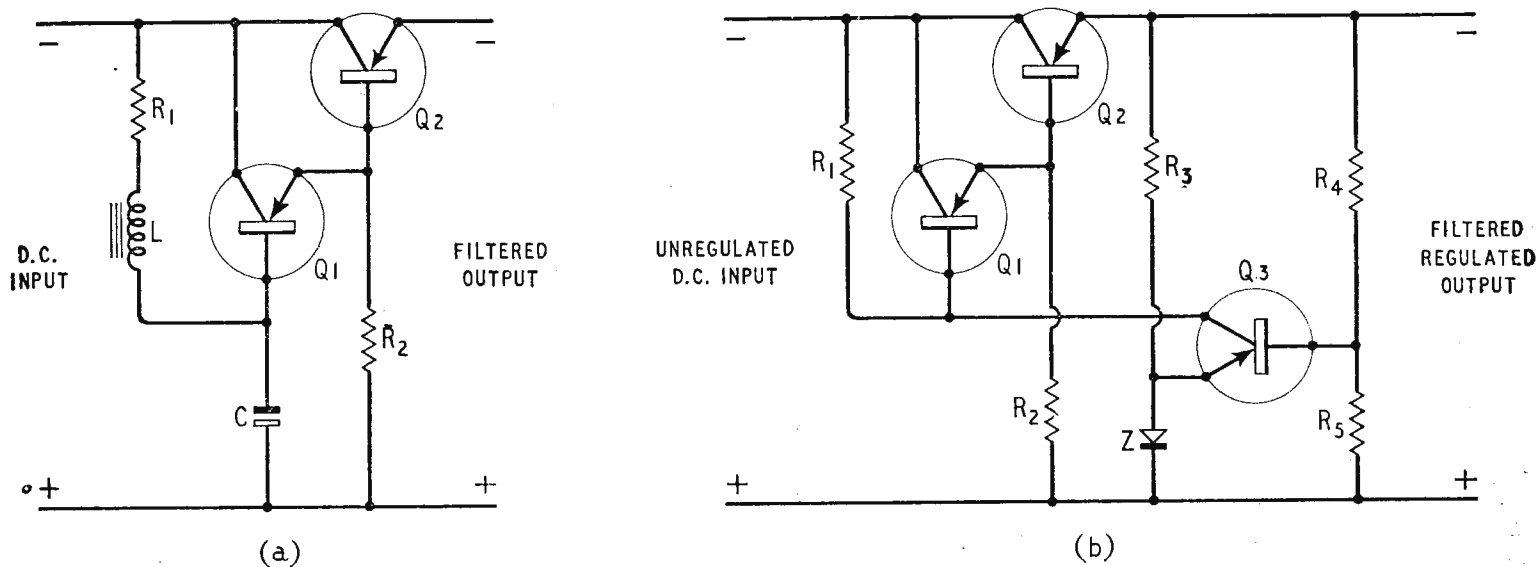

Fig. 7. Accessories for use with SCR power supply. (a) Electronic filter. (b) Transistor regulator.

diagrams are self-explanatory in most respects. When a positive sine-wave voltage is applied to one SCR, its anode voltage rises and the gate circuit capacitor charges up until at a critical point in the cycle the combination of high anode voltage and moderate gate current are sufficient to initiate the trigger action. With a heavy load current, firing must take place early in the cycle and a low gate-circuit resistance is required so that the CR time constant is very short. The gate circuit waveform shows a small step at the instant of firing. On light loads the gate circuit external resistance is much larger, leading to a longer CR time constant and less steeply rising and falling waveforms.

Rather more complex waveforms are observed in the circuit of Fig. 4. They are shown in Fig. 6. The gate circuit waveform is flat-topped over most of its duration at both light and heavy loads. Varying the value of the charging resistance moves the firing point along in time. The effect is observable as a movement of the step along the flat top of the trace. Various small transients are due to the sudden switching of quite large currents by the SCRs.

Comparison of SCR and Transient Regulators:—In cases where a very large d.c. power output is required, particularly at a high voltage, the advantage lies with controlled rectifier units. Outputs of tens of kilowatts are known to be practical and this does not represent an ultimate limit. Modern SCRs promise to be competitive with grid controlled mercury arc rectifiers, thyratrons and ignitrons. Efficiency is very high and there are no severe temperature limitations of the type which restrict the use of germanium transistors.

Voltage control units which use a series regulator transistor are highly efficient when operating at the maximum rated output voltage. Here the voltage drop across the regulator transistor is quite small and even at full load it dissipates only low power. Lower voltages are achieved by causing a larger voltage drop across the series element and at full load current the power loss is large and it is difficult to dissipate the generated heat.

A good transistor regulator will provide a d.c. output of extremely low impedance and practically free from ripple. It will compensate both for load

and line voltage changes, whereas the SCR unit has a higher ripple voltage and although it will compensate or over-compensate for load variations it will not correct for off line voltage fluctuations. It could easily be made to do so.

Accessories for SCR Power Supplies:—Fig. 7 shows two useful ancillaries for use with SCR regulated power supplies. The first, shown at (a) is an electronic filter which will reduce by a factor of one hundred or more the output ripple on any poorly filtered but well-regulated supply. Here Q_1 and Q_2 form a compound-connected transistor pair having a current gain almost equal to the product of the individual gains. The base bias to Q_1 is supplied through R_1 and L and is smoothed by a very large electrolytic capacitor C . So much forward bias is applied to Q_1 that it draws sufficient collector current, supplied to the base of Q_2 , that the latter is almost saturated and is operated with a collector-to-emitter potential of two or three volts only. The energy dissipation in Q_2 is relatively low even when it is supplying a load current of the order of 10 amperes. If the d.c. source supplying Q_1 and Q_2 has a good voltage regulation, losses in these transistors remain acceptably low under all load conditions.

In Fig. 7(b) a conventional series transistor regulator is shown. This employs a compound-connected pair of transistors as the series regulator element. Base bias for Q_1 is provided by R_1 and Q_3 , acting as the arms of a potential divider. A Zener diode Z provides a fixed emitter voltage to Q_3 . The base bias is taken from the junction of R_4 and R_5 . This bias will tend to vary in accordance with any change in the d.c. output voltage. There will be a corresponding change in collector current which alters the bias of Q_1 in such a way as to compensate for the load-voltage change. Ripple reduction is effected by the same negative feedback mechanism.

In some cases it may be worth while to add one or both of the units in Fig. 7 to a high-power SCR d.c. supply system. Well filtered and closely regulated power could then be supplied to equipments known to be sensitive to voltage fluctuations. At the same time, high-power devices could be supplied direct from the main unit, bypassing the regulator stages.

WORLD OF WIRELESS

Relay

THE U.S.A.'s second communications satellite, Relay, which was launched from Cape Canaveral on December 13th, was initially inactive because of an abnormal drain on its storage batteries. A report from R.C.A., the designers, states that the cause of the low battery voltage appears to have been due to the improper functioning of the voltage regulator of the number one communications transponder.

Difficulties have also been encountered with Relay responding properly to commands. However, by using the number two transponder and employing a special command sequence whereby the telemetry encoder does not operate when the transponder is commanded to turn on, successful communications tests were begun on January 3rd, and television exchanges between Andover, Maine, and Europe took place on January 9th.

There is a separate voltage regulator for each communications transponder. Each voltage regulator acts also as an on-off switch for the particular transponder it powers and, as a consequence, its condition should be either on or off. The telemetry indicated a voltage from this regulator when it was nominally in the off position: still the power supply for transponder number one was considerably hotter than the rest of the satellite. It was deduced that the voltage regulator for transponder number one was conducting, although its command state was "off" and that this was partially powering the transponder and draining the batteries.

Interrogation was stopped for several days and when resumed on December 27th, all items were found to be normal except for a small drain in the voltage regulator. After another rest period transponder number two was successfully switched "on" on January 3rd.

Radio Conference

THE tenth Plenary Assembly of the International Radio Consultative Committee (C.C.I.R.), the venue of which was recently changed from New Delhi to Geneva, opened on January 16th and is scheduled to last a month. It is being attended by delegates from some 54 member countries of the International Telecommunication Union and representatives of international organizations and "operating agencies." Its agenda covers the technical aspects of the whole field of radio communication, including "space."

At these assemblies, which are held every few years, the last being in Los Angeles in 1959, the work of the 14 study groups is considered, recommendations for submission to the I.T.U. are adopted and a programme of study for the next few years covering problems of transmission and reception is drawn up.

The U.K. delegation, which is headed by Capt. C. F. Booth, totals 39 and includes representatives from the Post Office, B.B.C., I.T.A., D.S.I.R., N.P.L., R.A.E., Foreign Office, Joint Communica-

tions Electronics Board, B.R.E.M.A., E.E.A., Cable & Wireless, International Marine Radio Company and Marconi International Marine Company. Dr. R. L. Smith-Rose is attending as observer from the Inter-Union Committee on Frequency Allocations for Radio Astronomy and Space Science (I.U.C.A.F.).

B.B.C.'s Second Television Service.—Orders to the value of about £1.25M have been placed with Marconi's and Pye by the B.B.C. for u.h.f. transmitters for twelve stations in readiness for the introduction of its second television service (on 625 lines). Marconi's and Pye are each supplying twelve vision transmitters with associated sound transmitters and combining filters. Equipment will be installed in duplicate at each station.

Purchase Tax.—The eleventh post-war change in purchase tax on domestic sound radio and television receivers and radiograms was announced by the Chancellor of the Exchequer on December 31st. Domestic receivers, radiograms, valves, loudspeakers (not over 10in diaphragm), kits of parts, pickups and records are now chargeable at 25% instead of 45%.

A data processing centre to handle telemetered information from satellites is to be set up at the Radio Research Station of the D.S.I.R. at Slough. It is planned to be ready to handle the "raw" data from the second Anglo-American satellite, S52, to be launched next year. This tape-recorded information will come from receiving stations all over the world which, in the case of the first Anglo-American satellite Ariel, has to be processed initially in the U.S.A.

Wire Broadcasting in Germany.—There are now only about 90,000 subscribers to West Germany's radio relay service which is operated by the Bundespost. The number is said to be decreasing by about 1,000 a month and the Bundespost, therefore, plans to close it down. The city with the largest number of subscribers is Hamburg with 16,000.

Amateur television enthusiasts can now obtain from E.M.I. Electronics 1-in vidicon camera tubes at £12 each. These tubes (Type 10667M) have minor blemishes but are quite suitable for amateur experimental purposes.

The I.T.A. plans to open its second transmitter in **Northern Ireland**—at Strabane—on February 18th. It will operate in channel 8 (vertically polarized) with a maximum vision e.r.p. of 90 kW.

Paper tape handling convention showing which way round the tape should be fed into the reader and also on which side is the "printed face" has been prepared by the Data Processing Section of the Electronic Engineering Association. Copies are available from the Technical Secretary of the Association at 11 Green Street, Mayfair, London, W.1.

The Radio Society of Ceylon has published a call-book and amateur radio directory compiled by Ian D. Wollen (4S7IW). It lists the officers of the Society, also names, addresses, interests and call signs of the transmitting amateurs of Ceylon.

Stereo Broadcasting.—A second series of field trials of the Zenith-GE stereophonic broadcasting system (from Wrotham, Kent, using the Third Programme transmitter—91.3 Mc/s) has been started by the B.B.C. and will continue until about the end of March. There are three morning transmissions each week:—Sunday 10.00 to 10.30; Wednesday and Saturday, 11.00 to 11.30.

African V.H.F./U.H.F. Broadcasting.—A conference is to be held in Geneva, beginning on April 29th, to plan frequency allocations in the v.h.f. and u.h.f. bands for sound and television broadcasting stations in Africa. The conference is being organized by the International Telecommunication Union, and will be attended by representatives of about 30 countries in the continent.

Public Address Exhibition.—The Association of Public Address Engineers is holding its annual exhibition of public address equipment on March 6th and 7th at the Kings Head Hotel, Harrow-on-the-Hill, Middlesex. It will be open each day from 10 a.m. to 6 p.m. and admission is by ticket obtainable free from the A.P.A.E., 394 Northolt Road, South Harrow, Middlesex, or on the presentation of a business card.

R.S.G.B. Membership.—The annual report of the Radio Society of Great Britain records a total membership of 11,135 at June 30th, 1962, compared with 10,644 a year earlier. Of the total of 9,622 U.K. licensed amateur (sound) transmitters at that date, 6,910 were members of the society. It is noteworthy that at June 30th there were also 102 amateur (television) licences.

The first of **West Scotland's** low-power television and v.h.f. sound relay stations—at Fort William, Inverness.—began test transmissions in December and will be brought into service by the B.B.C. shortly. The television transmitters operate in channel 5 and the sound transmitters on 89.3, 91.5 and 93.7 Mc/s. All are horizontally polarized.

I.T.A.'s growth in eight years from one station serving London to 21 stations serving 95% of the country's population is outlined in the booklet "The Authority's Stations." It contains coverage maps and brief details of all the transmitters and outlines some of the problems, including the prevention of interference with Continental stations, that had to be overcome in the planning of the stations. It costs 2s 6d from the I.T.A., 70 Brompton Road, London, S.W.3.

"**Technical Services for Industry**" is a guide to the technical services provided by the research laboratories of the Department of Scientific and Industrial Research and by the 52 industrial research associations which receive grants from D.S.I.R. The 104-page book, which is obtainable free from the D.S.I.R. Library, State House, High Holborn, London, W.C.1, also contains details of regional technical information services maintained by colleges and associations.

"**The Use of Electronic Valves.**"—This British Standards code of practice (CP 1005), first published in four separate parts, has been revised and is now available as one document (price 12s 6d). It is intended to give guidance to designers of equipment so that they may obtain optimum performance and life from the valves.

Watford College of Technology, Hertfordshire, has a 10-lecture evening course on design theory for semiconductor circuits beginning on January 30th and another on digitized control engineering beginning the following day. The fee for each course is 31s.

School Television.—The number of schools registered for the B.B.C.'s school television service, which is now five years old, is 4,364—an increase of 940 during the past year

CONFERENCES

V.H.F. Air/Ground Communications.—The International Civil Aviation Organization recently suggested that member States should further develop techniques for v.h.f. extended-range air-to-ground communications. International Aeradio Limited (40, Park Street, London, W.1) are therefore organizing a symposium on the subject to be held in London on May 7th and 8th.

Solid Circuits and Microminiaturization is the title of a national conference being organized by the West Ham College of Technology, Romford Road, Stratford, London, E.15, which will be held at the college on June 6th and 7th. The aim of the conference, over which G. W. A. Dummer, of R.R.E., will preside, is to bring together manufacturers and users of solid circuits. The fee, including luncheons and conference banquet, is 7gn.

Civil Aviation Electronics.—The I.E.E. Electronics Division is to hold a conference on Electronics Research and Development for Civil Aviation at Savoy Place, London, W.C.2, from October 1st to 4th. Particulars regarding the submission of papers and registration are obtainable from the institution.

Automatic Production.—The dates have now been announced for the I.E.E. symposium on Automatic Production in Electrical and Electronic Engineering arranged for October. They are 24th and 25th.

Dielectric Insulating Materials.—The I.E.E., in collaboration with the British Ceramic Society, Institution of the Rubber Industry, Plastics Institute, Plastics and Polymer Group of the Society of the Chemical Industry and the Society of Glass Technology, is arranging for 1964 a three-day conference covering the theory, properties, testing and uses of dielectric and insulating materials. It will be held in London from April 8th to 10th.

CLUB NEWS

Birkenhead.—A talk on two-metre operation will be given by H. Syngé (G3BOC) to members of the Wirral Amateur Radio Society on February 6th at 7.45 at Harding House, Park Road West, Clarighon.

Derby.—The month's meetings of the Derby and District Amateur Radio Society include the contest for the G5YY Trophy (Sunday, 3rd) and a demonstration of measuring equipment, for junior members (27th). Meetings are held each Wednesday at 7.30 at Room No. 4, M.U.O.F., 119 Green Lane, Derby.

Edinburgh.—The Rev. W. Ferrier (GM3BDA) will talk on 2-metre aeriels and propagation at the February 28th meeting of the Lothians Radio Society. The club meets at 7.30 in the Y.M.C.A., 14 South St. Andrew Street, Edinburgh 2.

Halifax.—Interference with television and sound broadcasting will be discussed by H. Swift (G3ADG) at the meeting of the Northern Heights A.R. Society on February 27th at 7.30 at the Sportsman Inn, Ogden.

Spenn Valley.—T. H. A. Withers, of Withers Electronics, will talk about converters, receivers and transmitters at the meeting of the Spenn Valley Amateur Radio Society on February 7th. A fortnight later the speaker will be S. Marsden, of Richard Allen Radio. Meetings are held at 7.15 at the Grammar School, Heckmondwike.

Worcestershire.—A meeting preparatory to forming a radio club in the East Worcestershire area is to be held on January 31st at 8.0, at the Dragoon Inn, Aston Fields, Bromsgrove. The sponsor is L. Hickingbotham (G3HZG) of 95 Oakenshaw Road, Redditch.

News from Industry

Radio Rentals Ltd. report a group trading profit, after all charges other than depreciation, of £6,701,615 for 1961/2—£204,000 higher than the previous year. Depreciation accounted for £4,272,509 (£4,121,284) and taxation £854,735 (£805,652), which after deducting a small sum for a "minority interest" left a net profit of £1,568,199 (£1,564,718).

Dictograph Telephones Ltd.—The consolidated profits of the group, of which Grampian Reproducers Ltd. is a subsidiary, for the year to August 31st 1962 amounted to £337,661 as against £326,322 the previous year. Profits after taxation totalled £188,091 as compared with £184,685.

RCA colour television receivers are now to be marketed in this country through RCA Great Britain. The price quoted is £385 net. The sets are continuously tunable over 70 six-megacycle channels from 470 to 890 Mc/s and also cover a specified channel in each of Bands I and III. They employ a 21-in tube.

Communication Systems International Ltd. has been formed to control Communication Systems Ltd. in this country and similar companies overseas. Each of these companies was a subsidiary of Automatic Telephone & Electric Co. Ltd. which merged with Plessey in 1961. Chairman of the new company is A. E. Underwood, who is also deputy managing director of the Plessey Company, and W. A. Travers is managing director.

Rank Kalee and Westrex are arranging a trading and manufacturing agreement under which Westrex will take over the servicing of all cinema sound and projection equipment for both organizations in the U.K. Rank Kalee will be the sole agents for Westrex sound recording equipment in the U.K. and certain overseas territories and Westrex will be responsible for the development and manufacture of the equipment.

GATAC (short for general assessment tri-dimensional analogue computer), owned by the Ministry of Aviation and jointly operated by E.M.I. and Whitworth Gloster Aircraft, will be one of the most advanced installations in Europe working on guided weapon design when a further bank of EMIac II modules is added shortly. It will then have over 1,300 computing units with numerous input and output facilities and nearly 200 EMIac electronic multipliers.

Decca have been granted in the High Court a five-year extension of a patent for Dectra the long-range version of the Decca Navigator system.

Anglo-Netherland Technical Exchange Ltd., manufacturers of Antex soldering irons, have moved their offices to Grosvenor House, High Street, Croydon, Surrey (Tel.: Municipal 2774) and their factory to larger premises on the Blackbushe Trading Estate, Yateley, Surrey (Tel.: Yateley 3030).

Advance Components brought into operation at the end of December their new 6,000 sq ft engineering laboratory at Hainault, Essex. G. F. Penver is chief engineer of the instruments division and D. R. Bridges of the Volstat division.

RCA and Philco (a subsidiary of Fords) have resolved their long-standing dispute on patent licensing. Under a joint agreement RCA receives non-exclusive licenses under all existing Philco and Ford patents relating to "radio purpose apparatus (including colour television), transistors and data processing equipment." Ford and Philco also receive similar non-exclusive licenses from RCA but excluding patents relating to colour television which will be available later "at the prevailing rate for such licenses." RCA will also be free, for the next five years, to use any domestic colour television patents issued to Philco on applications filed after the date of the agreement. It is understood that RCA has paid Philco \$9M for the rights received under this agreement.

Pye Telecommunications Ltd., of Cambridge, and the Aircraft Radio Corporation, of Boonton, New Jersey, have signed a ten-year agreement under which the Aircraft Radio Corporation will market Pye communications products throughout the United States. Pye have reciprocal rights to manufacture and sell the airborne products of A.R.C. (a subsidiary of the Cessna Aircraft Company).

Harting connectors, designed by Wilhelm Harting, of Espelkamp-Mittwald, Westphalia, West Germany, are to be manufactured in the U.K. by Electro Methods Ltd., of Stevenage.

Stewart Aeronautical Supply Company Ltd. (SASCO), of Surrey, are appointed exclusive sales representatives in England for the Defense Products Division of Fairchild Camera and Instrument Corp., of New York. The equipment to be handled includes data processing, display and interpretation systems; communication, special television and radar systems; and electronic control and ground support equipment.

Datapulse Incorporated, of California, U.S.A., manufacturers of a range of pulse generators and data equipment, have appointed as their U.K. sales representatives Livingston Laboratories, Ltd., 31 Camden Road, London, N.W.1.

J.F.D. Electronics Corporation, of New York, has appointed the Capacitor Division of Standard Telephones & Cables Ltd., Brixham Road, Paignton, Devon (Tel.: Paignton 58685), as official agent in the U.K. and E.F.T.A. for certain of its products. These include variable piston trimmer capacitors, metallized inductors, L-C tuners and delay lines.

OVERSEAS TRADE

Ghana has placed a £3M "turnkey" order with Marconi's for a three-station television service, a multi-transmitter internal and external sound broadcasting station, and microwave radio links between the stations. Each of the three television stations (at Accra, Kumasi and Sekondi-Takoradi) will employ 5-kW 625-line vision transmitters and 1-kW f.m. sound transmitters operating in Band I. Associated studios are to be built at Accra. The sound broadcasting station (at Ejura) will employ six transmitters operating on any frequency from 3.2 to 18 Mc/s. The 10-kW output will be fed to a vertical incidence aerial, supported on 14 masts, and the ionosphere reflected signals should give a good coverage of the whole country from the one site. To extend Ghana's external "voice of Africa" service (already radiated from Tema) two 250-kW h.f. transmitters are also being installed at Ejura.

Finland's Director General of Posts and Telegraphs has placed an order for five R/T transmitters, worth about £20,000, with British Sarozal Ltd.

Morocco has bought two instrument landing systems from Standard Telephones & Cables Ltd. They are for Casablanca and Rabat airports.

Personalities

Sir Robert Fraser, O.B.E., B.A., B.Sc., director-general of the I.T.A., has accepted the invitation to become president of the Television Society in succession to **Sir Harold Bishop**, C.B.E., M.I.E.E., who has served for two years. A graduate of the University of Melbourne Sir Robert later obtained his B.Sc. degree in economics at London University. From 1930/39 he was leader writer for the *Daily Herald* and for the major part of the war was director of the publications division of the Ministry of Information. From 1946 to 1954 he was director general of the Central Office of Information.

R. J. Lees, M.A., B.Sc., head of the Instruments and Air Photography Division of the Royal Aircraft Establishment, has been appointed director of the Signals Research & Development Establishment of the Ministry of Aviation, at Christchurch, Hants. Mr. Lees, who is 45, joined what is now the Royal Radar Establishment, Malvern, in 1939 where he remained until moving to the Royal Aircraft Establishment in 1959. While at Malvern he was largely concerned with work on guided missiles and in 1955 was appointed director of Scientific Research (Guided Weapons). From 1956 to 1959 he was head of airborne radar at R.R.E.

Following the re-grouping of the various Solartron Companies in the U.K. under a one-company structure as the Solartron Electronic Group Ltd., **L. B. Copestick**, formerly managing director of Solartron Research and Development Ltd., and **J. E. Cross**, formerly managing director of Solartron (Farnborough) Ltd., have resigned their directorships with the Solartron organization. **L. Malec**, M.B.E., formerly managing director of Solartron Radar Simulators Ltd., is taking a senior appointment on the Continent with Solartron's parent company, Schlumberger, and will be responsible for their electronics interests in Germany.

H. Faulkner, C.M.G., B.Sc.(Eng.), M.I.E.E., has retired from the directorship of the Telecommunication Engineering & Manufacturing Association and is succeeded by **R. A. Moir**, O.B.E., M.C., M.I.E.E., who was, until recently, a director of Standard Telephones & Cables. Mr. Faulkner has been director of the Association since his retirement from the post of deputy engineer-in-chief of the Post Office in 1953. He was with the Post Office for 40 years and was a member of the team responsible for the design of the Rugby radio station and was its first officer-in-charge (1925).

Stanley Gill, M.A., Ph.D., head of the Advanced Applications Group, of Ferranti's Computer Department, has succeeded **Dr. M. V. Wilkes**, of Cambridge University Mathematical Laboratory, as the U.K. member of the council of the International Federation for Information Processing. He is 36. After graduating at Cambridge he joined the National Physical Laboratory and later returned to Cambridge and obtained his Doctorate for research into methods of applying the Cambridge computer, EDSAC, to problems in mathematics and physics. During 1953/4 he spent 18 months in the U.S.A. and was visiting assistant professor at the University of Illinois. Dr. Gill joined Ferranti's in 1955.

G. H. W. Johnson, for the past two years chief executive and a director of the Marconi Marine Company's Norwegian associates the Norsk Marconikompani A/S, of Oslo, has been appointed management executive of the Marconi International Marine Company with particular responsibility for radar equipment sales in Europe. Mr. Johnson, who has retained his Norwegian directorship, joined Marconi's as a radio officer in 1938.

Dr. D. Gabor, F.R.S., Professor of Applied Electronic Physics at the Imperial College of Science and Technology, London, has joined the board of directors of the Fulmer Research Institute, Stoke Poges, Bucks.

Colonel E. N. Eford, O.B.E., for many years the manager of Marconi's Radar Division has retired but is being retained as a consultant. In 1960 he relinquished his position as manager of the division to take up special duties for the managing director, principally in the defence field.

F. Langford-Smith, B.Sc., B.E., has, because of ill-health, relinquished his position as chief of the technical publications department of the English Electric Valve Company and has returned to his native Australia. He came to England towards the end of 1956 and is well known as the author of the "Radio Designer's Handbook." In 1959 he was elected an honorary member of the Audio Engineering Society of America "in recognition of the importance of his book . . . to the education of a generation of audio engineers." He is succeeded at E.E.V. by **P. G. Durham** who has been his chief assistant for three years. Prior to joining the company Mr. Durham was, from 1942, with Standard Telephones & Cables where he was originally on the engineering staff and subsequently in charge of technical information.



H. Faulkner



R. A. Moir



F. Langford-Smith



P. G. Durham

Sir Harold Bishop, C.B.E., F.C.G.I., B.Sc.(Eng.), M.I.E.E., Director of Engineering in the B.B.C., will retire on May 10th, having completed forty years' service. Educated at the City and Guilds College, he spent two years with H.M. Office of Works and a year with Marconi's before joining the British Broadcasting Company. He was appointed senior superintendent engineer in 1923, assistant chief engineer 1929, chief engineer in 1943 and has been Director of Engineering since 1952.

F. C. McLean, C.B.E., B.Sc., M.I.E.E., succeeds Sir Harold as Director of Engineering. After taking his degree at Birmingham University, Mr. McLean joined Standard Telephones & Cables in 1925. In 1937 he joined the B.B.C. and was appointed assistant chief engineer in 1951, deputy chief engineer in 1952, and has been deputy director of engineering since 1960.



F. C. McLean



Dr. K. R. Sturley

The new deputy director of engineering will be **M. J. L. Pulling**, C.B.E., M.A., M.I.E.E. Educated at Marlborough College and King's College, Cambridge, Mr. Pulling was with Murphy for a few years before joining the B.B.C. in 1934. He became superintendent engineer (recording) in 1941, senior superintendent engineer (television) in 1949, controller, television service engineering in 1956, and for the past year has been assistant director of engineering. **D. B. Weigall**, M.A., M.I.E.E., will be the new assistant director of engineering. On leaving Oxford University in 1933 he joined the B.B.C. as a student apprentice. He was seconded to the Malaya Broadcasting Corporation as chief engineer from 1940 to 1942. For the past two years he has been in the External Broadcasting Engineering Department and became chief engineer, external broadcasting, last May. His successor is **K. R. Sturley**, Ph.D., B.Sc., M.I.E.E., head of the Engineering Training Department since he joined the B.B.C. in 1945. Dr. Sturley graduated at Birmingham University and joined the staff of the Marconi College in 1936.

B. N. MacLarty, O.B.E., M.I.E.E., engineer-in-chief of Marconi's W/T Company since 1954, has been appointed engineering consultant to the company and will be undertaking special full-time duties for the managing director. He joined the company in 1921 as a development engineer but went to the B.B.C. in 1926. He rejoined the company as deputy engineer-in-chief in 1947. The title engineer-in-chief is being discontinued and **E. Eastwood**, C.B.E., Ph.D., M.Sc., M.I.E.E., has been appointed Director of Engineering and Research. Dr. Eastwood joined Marconi's in 1948, from the Nelson Research Laboratories of the English Electric Company. In 1954 he became chief of research and in 1961 director of research. **R. J. Kemp**, formerly deputy engineer-in-chief of Marconi's, which he joined in 1917, is appointed deputy director of engineering and research. From 1930 to 1939 he was engineer-in-charge of television research and was chief of the company's Great Baddow Research Station from 1948 until 1954.

J. C. Fenning describes in this issue the Post Office television detector vans on the development of which he has been engaged in the Inland Radio Planning and Provision Branch. He joined the Post Office engineering department in 1941 as a youth-in-training at the Research Station, Dollis Hill, and since 1956 has been engaged on the development of radio interference tracing and measuring equipment.

OBITUARY

J. Donegan, B.Sc., A.C.G.I., D.I.C., of Thorn-A.E.I. Radio Valves and Tubes Ltd., died on November 21st, aged 58. After graduating from City & Guilds College, he spent all his working life in the radio valve and cathode-ray tube industry, joining Cosmos Lamp Works Ltd. (now part of A.E.I.) in 1929 to take charge of the test department. He became successively development engineer, chief engineer (valves) and product engineering manager, which post he relinquished a few months ago to assume special duties within the company. He was a member of the engineering advisory committee of the British Radio Valve Manufacturers' Association and of various Government valve committees.

NEW YEAR HONOURS

A number of well-known names in the world of wireless appear in the Queen's New Year Honours List, they include:

Knighthood

R. E. Lindsay Wellington, C.B.E., Director of Sound Broadcasting, B.B.C., who is retiring in August.

C.B.E.

A. H. Cooper, B.Sc., technical director, E.M.I. Electronics Ltd.

O.B.E.

H. G. Campey, head of publicity, B.B.C.

Wing Cdr. M. E. Claxton, B.Sc., M.Brit.I.R.E., No. 2 Radio School, R.A.F., Yatesbury.

O. J. Crompton, M.Eng., M.I.E.E., director and general manager, British Insulated Callender's Construction Company.

H. G. Hopkins, B.Sc., Ph.D., M.I.E.E., senior principal scientific officer, D.S.I.R. Radio Research Station.

W. S. Melville, B.Sc., M.I.E.E., manager, Military Radar Engineering Department, A.E.I., Leicester.

M.B.E.

R. L. Angrove, station commander, Forces Broadcasting Service, Tripoli.

H. W. Boutall, A.M.I.E.E., senior engineer (contracts), I.T.A.

A. R. Cork, deputy production manager, E.M.I. Ltd., Hayes.

I. T. Davies, purser-radio officer, s.s. *Jason*, Alfred Holt and Company.

R. A. Rowden, B.Sc., M.I.E.E., head of field strength section, Engineering Research Department, B.B.C.



A. H. Cooper (C.B.E.)

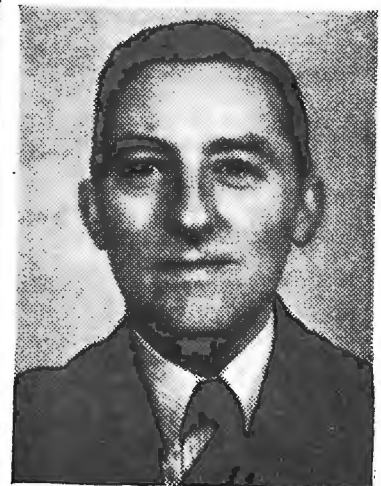

R. A. Rowden (M.B.E.)

'ENGLISH ELECTRIC'

New English Electric Vacuum Variable Capacitors Early delivery from wide range

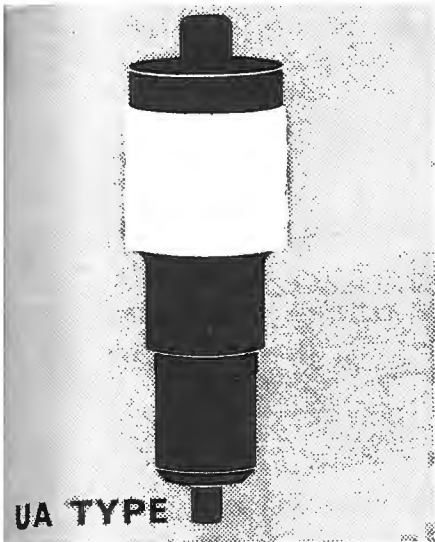

UA TYPE

An entirely new series of
Vacuum Variable Capacitors
has now been introduced by
English Electric Valve Co. Ltd
giving

- 40 ampere (r.f.) rating (r.m.s.)
- capacitance range covering
5 to 750 pF
- up to 20 kV (peak) operation

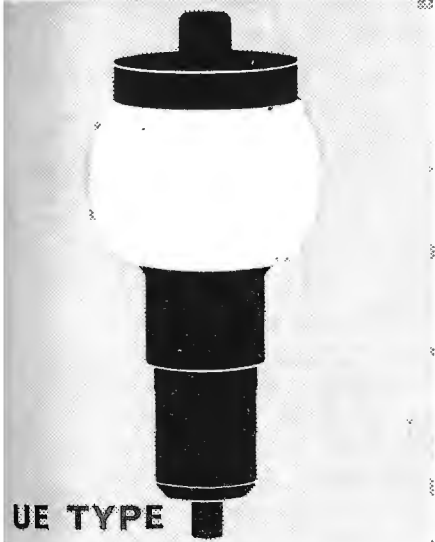

UE TYPE

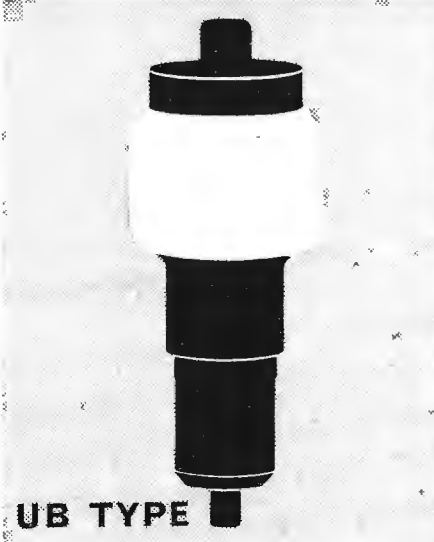

UB TYPE

Vacuum Variable Capacitors have
many advantages over conven-
tional air or gas-filled capacitors
including:

- Compactness
- Extremely low power factor
- Low self-inductance and stray
capacitance
- No electrostatic dust precipi-
tation on plates
- Ease of installation
- Self-healing properties in
cases of accidental voltage
overload

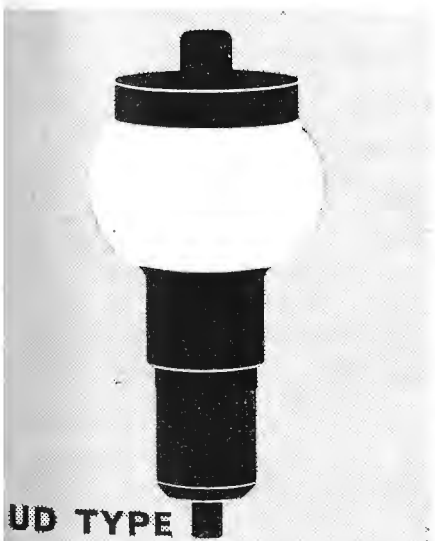

UD TYPE

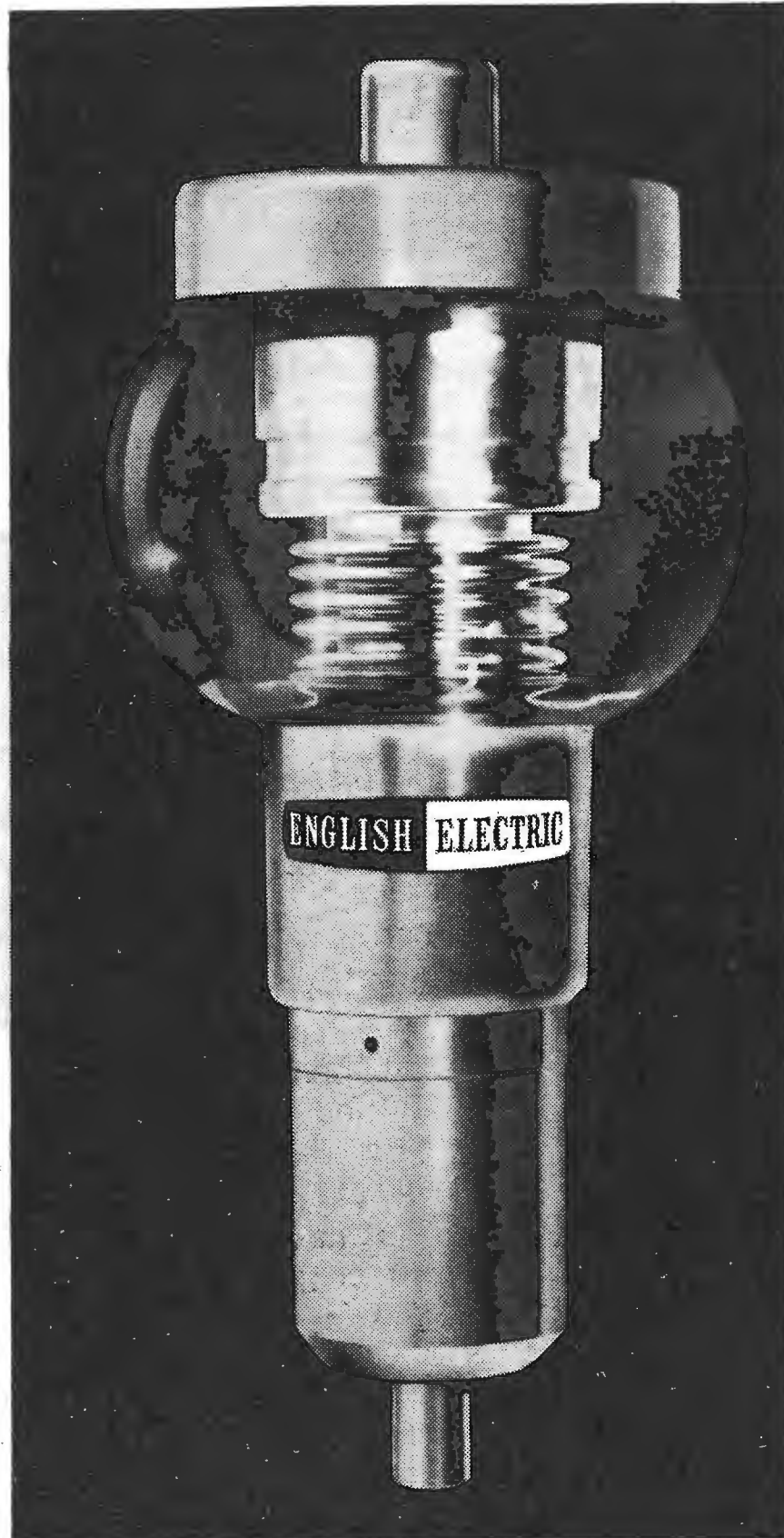

Further information on this new
series and the complete range of
types, with capacitances up to
2000pF, is available on request.
Enquiries are also invited for
special designs, to suit individual

English Electric Valve Company Limited

AGENTS THROUGHOUT THE WORLD

Chelmsford, England. Telephone: Chelmsford 34

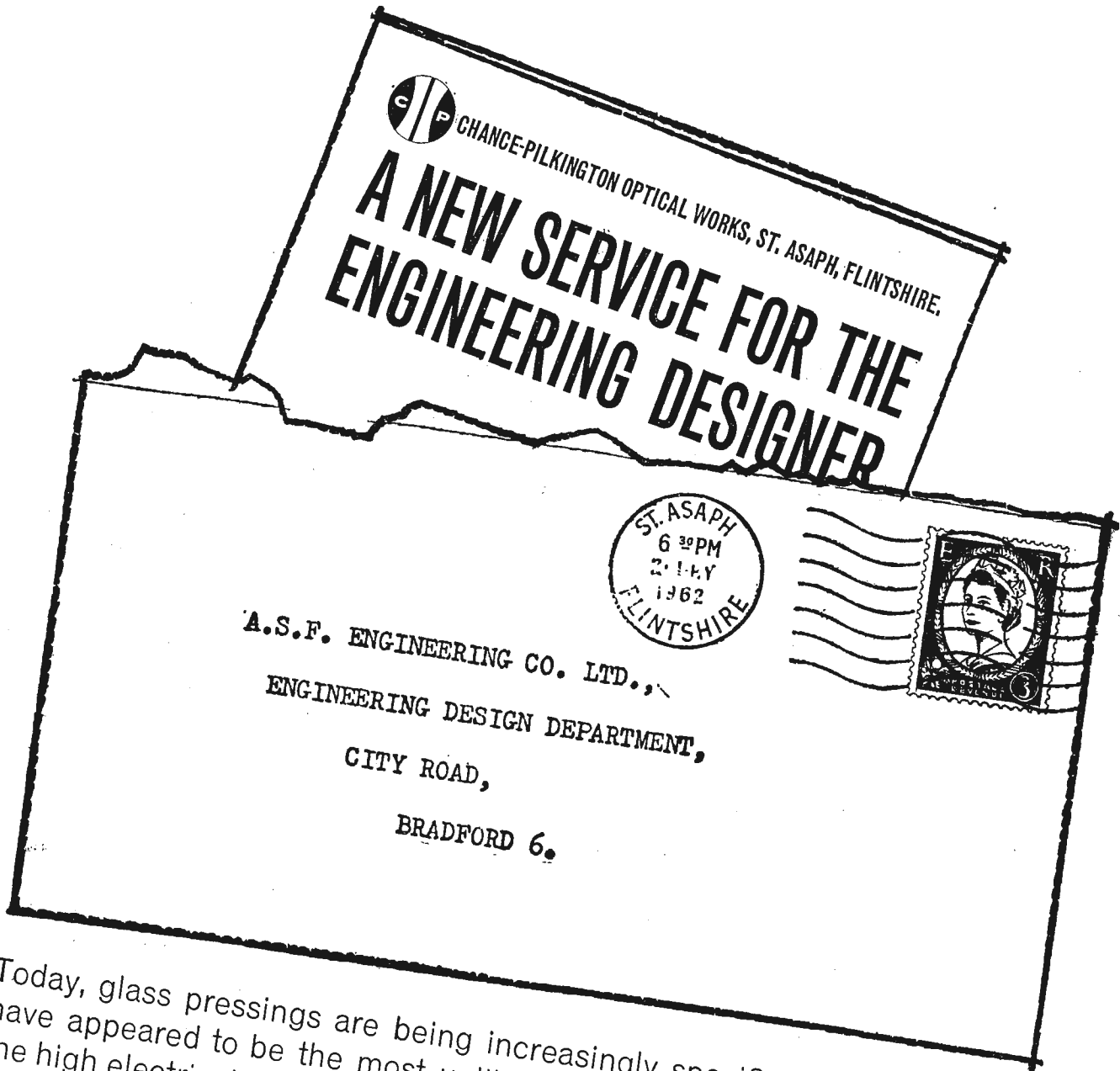

Today, glass pressings are being increasingly specified for what might have appeared to be the most unlikely components. The reason is that the high electrical, thermal, and abrasive resistant characteristics of glass can meet exacting specifications better than most other materials, whether or not its transparency is required. Chance-Pilkington Optical Works have a world-wide reputation for the quality and precision of their glass pressings for optical and ophthalmic use. Because of this their advice has been often asked on the use of pressed glass components in engineering and industrial design. **Now, Chance-Pilkington announce the formation of a new division, set up to deal with such inquiries, and to provide a complete development and production service.** Manufacture will be by the most modern processes, linked with the stringent quality and specification control on which Chance-Pilkington's international reputation has been established. Next time the question "What material?" crops up, telephone St. Asaph 3281 and talk to Ken Appleton, Sales Manager. Glass may well give you a better answer than you ever thought possible.

C/P CHANCE-PILKINGTON OPTICAL WORKS, ST. ASAPH, FLINTSHIRE • One of the great Pilkington glassmaking companies

H.F. PROPAGATION IN 1962

PREDICTIONS AND PRACTICE COMPARED

By P. A. C. MORRIS,* B.Sc., A.M.I.E.E.

THE year 1962 brought a welcome respite from the headlong decline of the present sunspot cycle, the nineteenth since records began in 1749. With the running average sunspot number standing at about 43 when the year began and the minimum of the cycle (if of average duration) not due until 1965, the only consolation was that the sunspot number cannot drop below zero. Although the running average number for the year-end cannot be known for some months yet there has been a distinct levelling-off in the cycle's decay. This has allowed some opportunity for users of the h.f. band to explore their frequency allocations in the lower part of the spectrum and to construct aeriels suitable for these. Meanwhile the number of services operated has steadily increased.

The Ionospheric Index.—The sunspot number is the best-known index of solar activity but it is based on visual observation of the sun and not on the flux of ionizing radiation which is appropriate to radio communications. An

index much more closely correlated with the state of ionization is the Ionospheric Index (IF2) of Minnis and Bazzard¹; it is based on analysis of the measured critical frequencies at 11 ionosonde stations throughout the world. The values of this parameter have been provided by the Radio Research Station, Slough, and they are shown along with the sunspot number and their running averages in Fig. 1. The IF2 curve also shows the "levelling-off" in 1962.

Magnetic Activity.—After having declined fairly steadily since the end of 1959 the degree of magnetic activity took a sharp and ominous upswing in mid-1962, although it has since subsided. Fig. 2 shows the number of days per month on which activity was greater than an arbitrary datum. The disturbed days are now showing a strong tendency to follow the 27-day re-

currence cycle indicating that they may be connected with the "M-region" storms which were such an unwelcome influence on radio propagation during and around 1952 in the last solar cycle.

MUF: Predictions and Practice.—The decline of the solar cycle between 1958 (maximum) and 1962 was, of course, reflected in a reduction of the predicted standard maximum usable frequencies (MUFs) for actual radio circuits. The magnitude of the reduction varied between about 10 and 55% depending on location, season and route length but was generally more serious during local night.

In general, the actual usage of frequencies has followed this change, but in certain circumstances it has been found that although the predicted MUFs have steadily dropped the higher frequencies have remained in use. This is of great interest to some operators who may, therefore, avoid using the lower congested bands with a resulting benefit to all users

*Cable & Wireless Ltd.

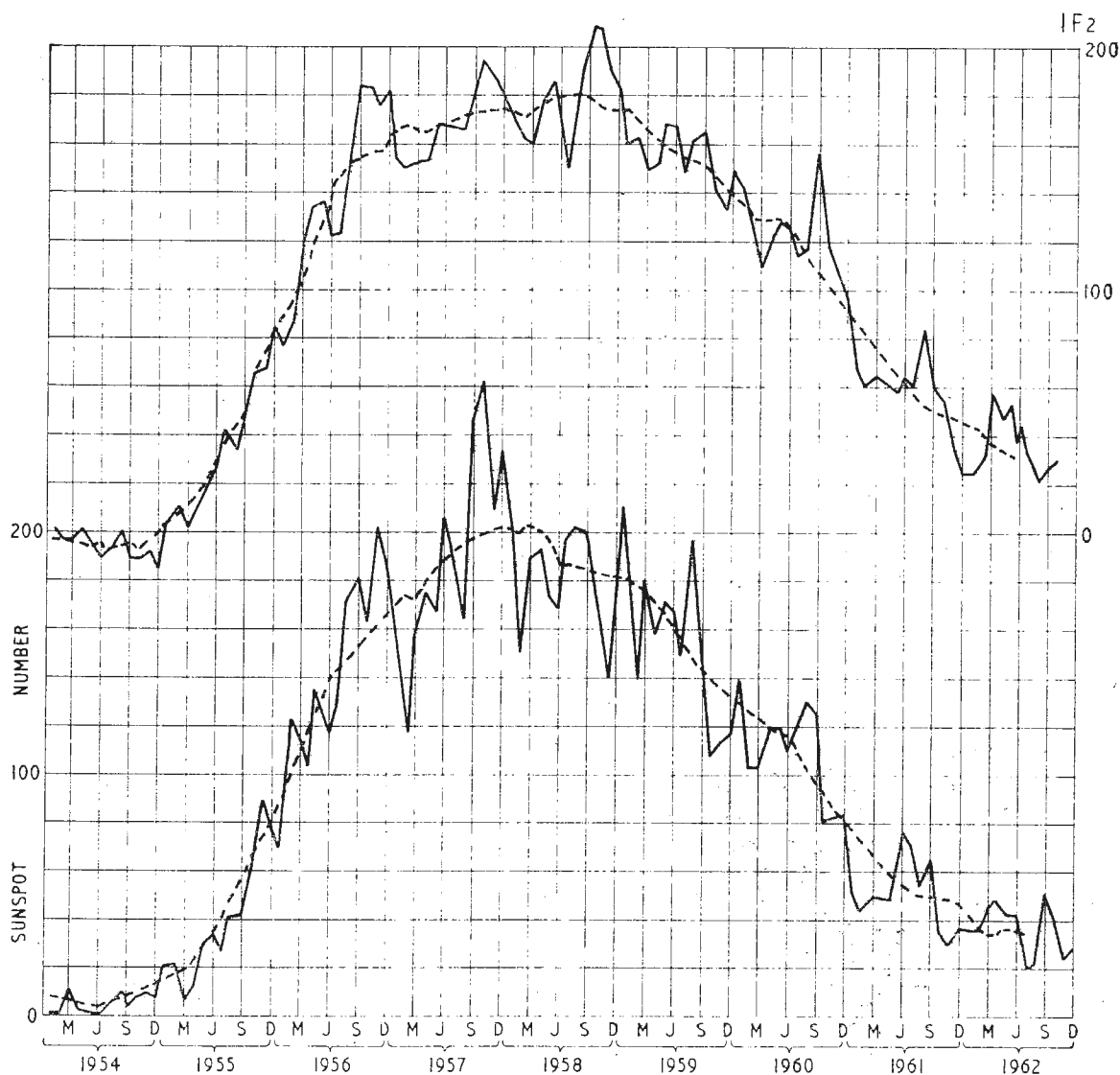

Fig. 1. The monthly values and (dashed) the running averages of the ionosphere index (IF2) and the sunspot activity for the past 9 years.

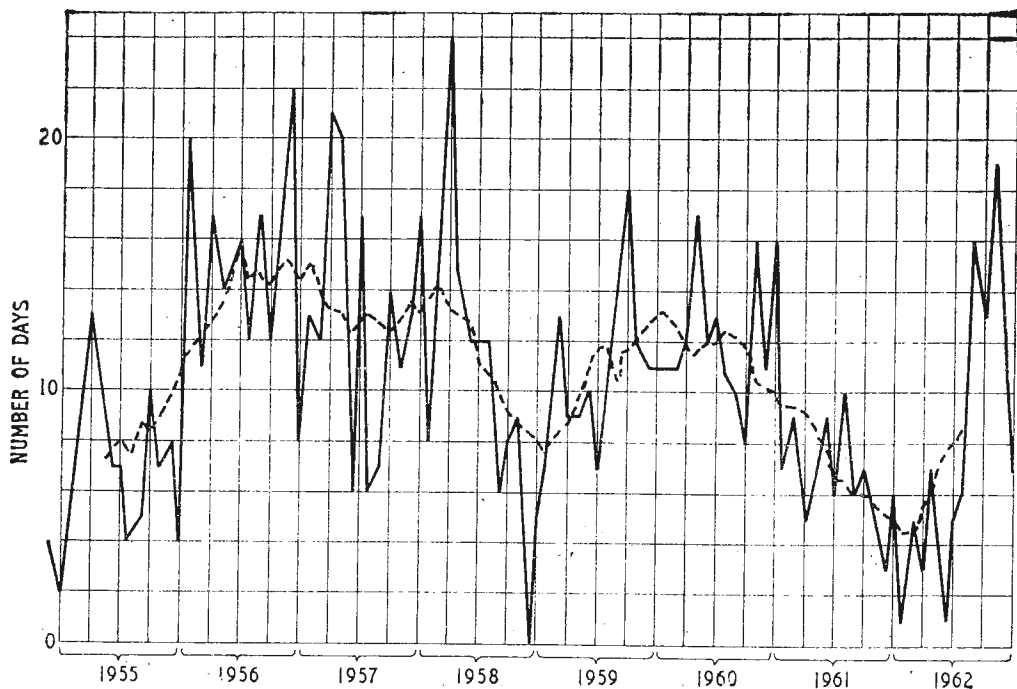

Fig. 2. The number of magnetically disturbed days per month from 1955 to 1962.

of the spectrum; a digression on this subject might be in order.

First, there are routes for which the daytime MUF was so high in 1958 that, even by 1962, the highest assigned frequencies were still usable. In the "maximum" years the predicted MUF on the Hong Kong-Bombay route, for instance, often reached 50 Mc/s; in 1962 it regularly exceeded 30 Mc/s and assignments over 24 Mc/s are still being used. This applies to similar low-latitude routes of intermediate length (of the order of 4,000 km).

Secondly, there are many cases where a reduction of the predicted MUF has not been followed by the use of lower frequencies because certain propagation modes which have so far been excluded in preparing the predictions have actually exerted a controlling influence. The normal prediction methods generally employed only consider F2-layer modes and even then exclude layer-tilts, scatter and off-bearing propagation. Some modes depend upon sporadic-E ionization, for example, which is largely independent of the sunspot cycle so that its influence becomes more important towards the minimum of the solar cycle when the F2 layer is weaker. The incidence of sporadic-E is greatest in (local) summer daytime and during the last sunspot minimum the extensive use of daytime frequencies considerably above the predicted MUF was attributed to this cause². During last summer this effect was again noticed and it will be beneficial to bear this in mind when referring to predictions in the coming summer. It has recently been suggested³ that MUF enhancements may often be due to effective layer tilts resulting from the difference in ionization at the two ends of a path. Some such mechanism might be invoked to explain the frequent reports of enhanced MUFs at night-time on certain routes, but it is not yet possible to generalize about this.

The amount of use made of frequencies above the predicted MUF during 1962 leads one to suspect that if there was a fuller understanding of when and where to expect these effects we might be able to ease the growing problem of congestion in the lower bands. It is now possible to examine mode structures with the aid of an oblique incidence iono-

sphere sounder which consists of a pulse transmitter and receiver at either, or both, ends of a circuit. These are maintained in synchronism as they sweep through the entire h.f. band and produce a display showing the MUF at any moment. There are many problems concerning the integration of this equipment into a communications system but nevertheless the knowledge that there are "anomalous" propagation modes is some encouragement to experiment with frequencies above those predicted, particularly in the sunspot minimum years.

Frequency Usage.—Although considerable use has been made of frequencies higher than those predicted there was a definite change towards the use of lower frequencies during the year. On

several main routes night-time frequencies well below 10 Mc/s were used for the first time since 1956 during the 1961-2 winter and their use became more regular as the 1962 winter advanced. Several factors prevent these frequencies from being as useful as one might expect—lower aerial gain, higher radiation angle, higher atmospheric noise and generally more interference—so that a good deal of use has still been made of the 10 Mc/s frequencies during those nights on which conditions allowed.

Fig. 3 compares the predicted MUF curves relating to a typical telegraph circuit between London and Nairobi for December, 1958 and 1962. It shows how the availability of the high daytime frequencies has been reduced and also emphasizes the need for additional intermediate frequencies which can cover the transitions between day and night. In the writer's opinion the diurnal availability of continuous point-to-point circuits can best be improved by agility in the use of frequencies rather than, for instance, by using higher and higher transmitter power. In saying this one assumes that both transmitting and receiving aerials conform to the best present standards.

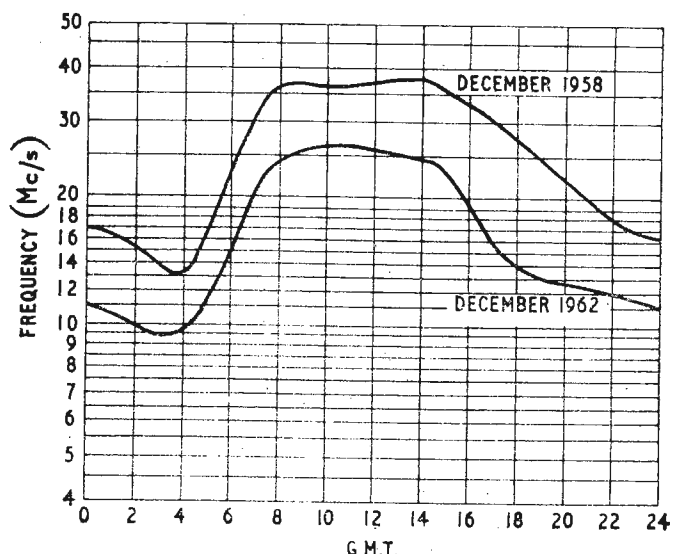

Fig. 3. Comparison of predicted MUF curves for London-Nairobi for December 1958 and 1962.

Conditions in 1963.—It would be misleading to suggest that conditions will be worse during 1963 since that implies that they were bad in the first place. There has actually been no dramatic decrease in the daily availability of main radio circuits in recent years although this satisfactory state of affairs has only been achieved by more intensive circuit control at radio stations coupled with increased work by those responsible for interference problems; in some cases, of course, improved equipment has also been a contributory factor.

The solar cycle will continue the downward trend

towards its minimum: one can only hope that the present cycle will prove to be one of short duration and that the minimum will come before eleven years are up in 1965.

REFERENCES

1. Minnis, C. M., and Bazzard, G. H., *J. Atm. Terr. Phys.* Vol. 18, 1960.
2. Hitchcock, R. J., Evans, G. O., and Naismith, R., *Proc. I.E.E.* Pt. B, Sept. 1960.
3. Williams, H. P., *Nature*, 20th Oct. 1962, page 256.

BOOKS RECEIVED

Fundamentals of Semiconductor & Tube Electronics, by H. Alex Romanowitz. A comprehensive first course in valve and semiconductor electronics. Beginning with a review of basic circuit theory and techniques of three laboratory instruments—the multimeter, cathode-ray oscilloscope and valve voltmeter—the book takes the student through the mechanics, electrical properties and applications of valves and semiconductors. A final chapter on microminiaturization gives the reader an insight into the latest developments. Mathematical considerations are kept mainly to algebra and simple trigonometry. Pp. 620. John Wiley and Sons Ltd., Gordon House, Greencoat Place, London, S.W.1. Price 62s.

Television Simplified (completely revised 6th edition), by Milton S. Kiver. Covers most aspects of television receiver techniques and principles including a consideration of colour television. The many circuit diagrams are well explained and only elementary knowledge is assumed of the reader. Pp. 637. D. Van Nostrand Co. Ltd., 358 Kensington High Street, London, W.14. Price 63s.

Radioarbogen, 62, edited by Geo Cortsen. Buyers' guide (in Danish) to sound radio and television receivers, record players and tape recorders for the 1962-63 season in Denmark, with a trade directory and statistics. Pp. 177. Rateksa, Puggaardsgade 2, Copenhagen V. Price Kr. 20.

Ocecode Navigation-Electronics, by R. J. Aalberts. An alphabetical list of 8,500 abbreviations, code names, symbols, etc., used in British and American electronic and navigational literature. Apart from its primary usefulness, it should provide ample material for an indictment of English terminological ambiguity. Example: AC=aero club, air commodore, air corps, air council, aircraft, aircraftsmen, alternating current, anode circuit/current, aerial current, anti-clutter, approach coupler, astronomical constant, Pp. 282. Oceco Technical Publishers, 35 Lysterbeslaan, Hilversum, Netherlands. Price 70s.

Using the Slide Rule in Electronic Technology, by E. Charles Alvarez. Very often the student's first acquaintance with the slide rule is coincident with his first excursions into the realms of electrical engineering and electronics. The author of this book sees this as an ideal situation and presents exercises in slide rule use as elementary electronic revision problems. The three basic slide rules (general purpose, duplex and log-log) are described and most fundamental measurements and calculations dealt with. Pp. 109. John F. Rider Publisher, Inc., 116 W. 14th Street, New York 11. Price \$2.50 paper back.

British Miniature and Subminiature Valves Data Manual 1962-63, edited by G. W. A. Dummer and J. Mackenzie Robertson. Collection of data from nine leading manufacturers of valves having bases not larger than B9A and including voltage stabilizers, reference tubes, tuning indicators, trigger tubes, thyrotors, etc. Equivalent tables which are not restricted to the smaller sizes are given. Pp. 921. Pergamon Press Ltd., Headingly Hill, Hall, Oxford. Price £10.

High Fidelity Pocket Book, by W. E. Pannett, A.M.I.E.E. Intended to provide a comprehensive treatment of current "hi-fi" techniques for the practising engineer, technician and dealer, its conciseness and clarity will help the home constructor and music lover. Pp. 314. George Newnes Ltd., Southampton Street, London, W.C.2. Price 40s.

Technique des Amplificateurs Basse Fréquence de Qualité, by Ph. Ramain. Complete treatise on the design of audio-frequency amplifiers employing valves. The book is divided into three parts, the first and largest dealing with basic principles of power amplifiers, the second with pre-amplifiers and equalizers and the third with radio feeder units, stereophony and high-quality systems in general. Is likely to become one of the standard reference books on the subject in the French language. Pp. 750. Editions Chiron, 40 rue de Seine, Paris 6. Price NF80.

INFORMATION SERVICE FOR PROFESSIONAL READERS

The reply-paid forms introduced recently to replace the postcards hitherto included have proved to be very helpful to professional readers, judging by the number of forms returned to us. This improved *Wireless World* service is therefore being continued.

The forms are on the last two pages of the issue, inside the back cover, and are designed so that information about advertised products can be readily obtained merely by ringing the appropriate advertisement page numbers. Space is also provided for requesting more particulars about products mentioned editorially.

By the use of these forms professional readers can obtain the additional information they require quickly and easily.

Commonwealth Telephone Cable

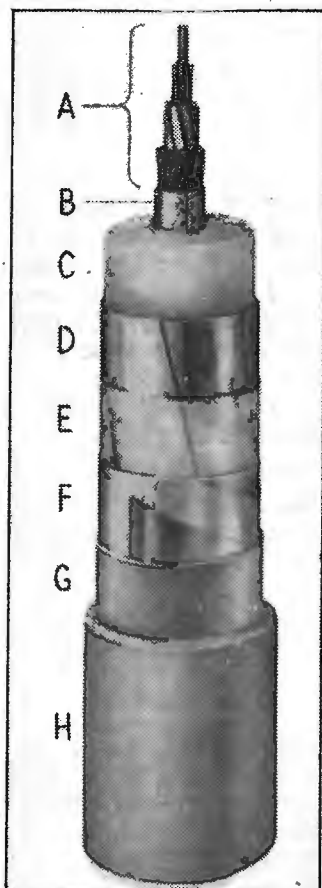

C.S. *Mercury* (above) the first cable-laying ship of Cable and Wireless Ltd., left London on December 17th on her first commission. The world's fastest cable-laying ship, she is now engaged in the laying of a 1,000-nautical-mile section of the 8,000-mile Commonwealth trans-Pacific (COMPAC) telephone cable. The loading of the cable and 49 repeaters lasted three weeks, day and night working. Each of the repeaters cost £20,000. The cable being laid on this voyage is for part of the Honolulu-Suva link. The lightweight coaxial cable (left), designed by the British Post Office and developed and manufactured by Submarine Cables Ltd., is unarmoured, a steel wire protection being unnecessary in deep quiescent waters. The strength member, consisting of high-tensile steel strands (A), runs through the tubular inner copper conductor (B) and aluminium tapes form both the return conductor (D) and a screening layer (F) which are separated by a polythene film (E). Polythene insulation (C), impregnated cotton tape (G) and an outer protective polythene sheath (H) completes the cable. When completed the 8,000-mile COMPAC cable system will be capable of carrying 80 simultaneous telephone conversations and any one of the 80 channels could carry up to 22 telegraph channels. The Suva-Auckland-Sydney sections (the cable and repeaters for which were made by S.T.C.) are already in service and COMPAC is due to be completed by next December. The South East Asia Commonwealth (SEACOM) cable is scheduled for completion in 1966.

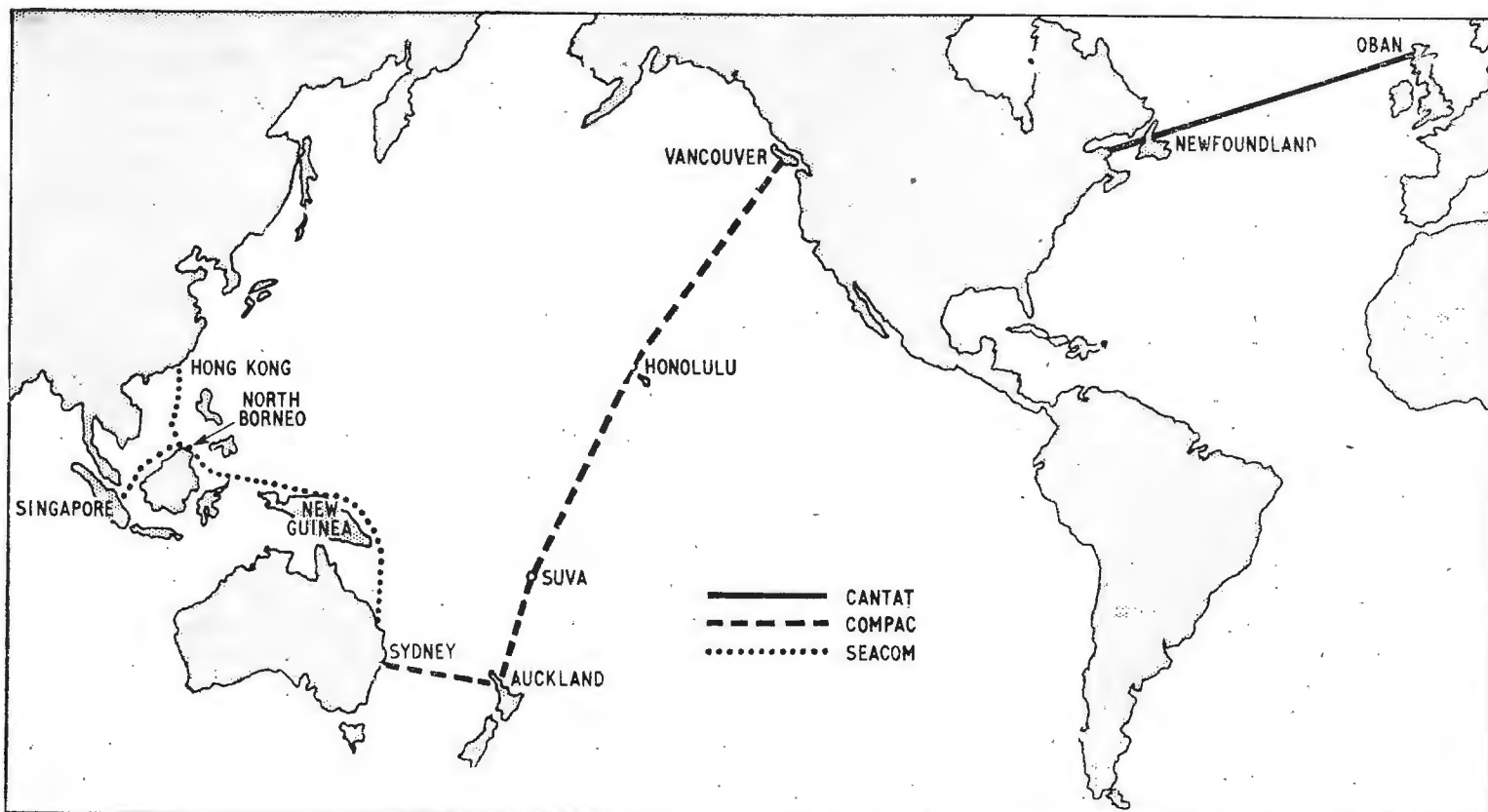

NEW G.P.O. SYSTEM
FOR TRACING
TELEVISION AND
V.H.F. SOUND RECEIVERS

By J. C. FENNING*



DETECTING UNLICENSED SETS

THE original Post Office system for the detection of unlicensed television receivers¹ which has been in use for ten years, relies on detecting the magnetic induction field from the line deflection circuits of the set. A modified communications type receiver tuned to the second harmonic of the line timebase frequency was employed to compare the e.m.f.s induced in horizontal screened loop aerials mounted at the front and rear of the detector car, on the nearside. When the car is immediately outside a house containing a working television receiver, the field strengths at the front and rear of the car are equal. A third loop mounted on the offside is used to determine whether the television receiver is on the nearside or offside of the car.

Following the introduction of alternative television programmes and the rapid increase in the number of television receivers in use, it has become increasingly difficult to detect unlicensed receivers with this system. A fundamental difficulty is that the line scan frequencies of the B.B.C. and the I.T.A. transmissions are not accurately synchronized, although each is nominally locked to the 50 c/s mains supply and the second harmonics of these frequencies may differ by several cycles per second. Thus if two television receivers, one tuned to the B.B.C. and the other to the I.T.A. are close together, the signal received by the detector will be the combined signal from the two timebases and the signal strength meter will follow the amplitude of the combined signal, i.e., it will respond to the beat frequency and field strength comparison will be impaired. Further difficulties associated with detecting radiation from the timebase circuits are the low field strengths encountered, due to improvements in television receiver

design and the high level of electrical interference occurring at very low frequencies, much of which is generated by the electrical circuits of the detector car itself and cannot be adequately suppressed. To overcome these difficulties a new system of detection has been developed.

All modern commercial television and v.h.f. sound broadcasting receivers use the superheterodyne principle and the new system relies on detection of the radiation from the frequency changing oscillators. The equipment consists of a direction-finding aerial and panoramic receiver mounted in an estate car. Owing to the variety of frequencies at which oscillator radiation can occur and the wide range of field strengths encountered, the new equipment is considerably more complex than that previously used.

Frequency Range of Radiations

Modern television receivers have a nominal vision i.f. of 34.65 Mc/s but older sets still in service employ a wide variety of intermediate frequencies. V.H.F. sound broadcasting receivers employ a 10.7 Mc/s i.f. and the oscillator frequency may be above or below that of the signal being received. At least two television channels (B.B.C. and I.T.A.) may be received in a given area on most receivers having a 16 or 34.65 Mc/s i.f.† and in fringe areas a particular programme may be received on two or more channels. Oscillator radiations from television and v.h.f. sound receivers therefore cover a wide frequency spectrum, the range being approximately 29-240 Mc/s. Receivers tuned to the same signal and having the same nominal i.f. do not radiate at precisely the same frequency. The frequency difference

* Post Office Engineering Dept.

† Most multi-channel sets employ these two i.f.s.

between adjacent receivers may vary from a few kilocycles to several megacycles, depending on the tuning adjustment of the receiver. Owing to temperature drift and manual operation of the receiver tuning, the oscillator frequency is not constant and generally a slow drift can be observed. The electrical coupling between the oscillator and aerial circuits in a receiver is small and oscillator radiation is mainly caused by chassis currents in the turret tuner and receiver, the short electrical paths favouring the radiation of harmonics of oscillators operating on the lower frequencies. By detecting these harmonics and the fundamentals of higher frequency oscillators the frequency coverage needed in a detection system may be reduced. The new equipment has therefore been designed to cover the range 110-250 Mc/s.

Field Strengths and Polarization

The signals being detected are spurious radiations from receivers and limits are set to the desirable amplitude of these radiations to minimize interference with other radio users. The limits specified by the B.S.I.² are equivalent to field strengths at a practical detection distance (10 metres) of approximately $20 \mu\text{V}/\text{m}$ in the bands used for TV and v.h.f. sound broadcasting and $50 \mu\text{V}/\text{m}$ outside these bands. The figures specified by the B.S.I. set a limit to the maximum field strength which may occur in any direction on an open test site. The radiation from a receiver which complies with these recommendations may be considerably lower than this in some directions, particularly when attenuated by the screening effect of a building. This signal absorption by buildings and other obstructions varies considerably when the transmission path is changed by moving the detector a few feet along the road.

As well as covering a wide frequency band, oscillator radiations are of random polarization.

The Aerial

Because the plane of polarization of a signal is usually rotated on reflection, a linearly polarized aerial may be less sensitive to a signal polarized at right angles to its plane of maximum response than to a reflection of the same signal. To be free from bearing errors, a direction finding aerial must, therefore, respond to signals of random polarization. For our purpose it must also have a wide frequency band, good directivity and gain, small size and freedom from beam splitting and tilting, i.e., the electrical and mechanical axes of the aerial must bear a constant relationship to each other when the frequency and plane of polarization are varied.

Ideally, the aerial should be circularly polarized but negligible errors result from the use of an elliptically polarized aerial of small axial ratio. Several types of aerial, including the conical helix were investigated, using scale model techniques at u.h.f. The aerial adopted consists of a tilted dipole in a corner reflector. End screens on the reflector mask reflections from the car roof. An optimum corner angle and angle of tilt of the dipole have been determined which give elliptical polarization over a $2\frac{1}{2}:1$ frequency range, without serious degradation of directivity and gain. A useful frequency range from 110 to over 250 Mc/s has been achieved, the lower frequency limit being set by the maximum



Operating the panoramic receiver and aerial control in one of the new television detector cars.

permissible dimensions of the aerial. The gain of the aerial varies with frequency and polarization but it is approximately equal to that of a resonant dipole. The half-power beam-width varies between 45° and 60° over most of the frequency range but it increases to 90° at the lower end. The ratio of amplitudes of the main response to all other responses ("front to back ratio") is generally greater than 20 dB but it falls at lower frequencies when the plane of polarization of the signal lies within certain narrow angles.

With a good signal, a bearing accuracy of about 5° may normally be achieved and even when the signal-to-noise ratio is poor, the mean of several bearings will usually give this order of accuracy. For example, this means that location from a single bearing at a distance of 40 feet could be within 3 to 4 feet. By taking bearings from different positions, the operator can readily determine in which room of a house a receiver is operating.

To permit continuous rotation of the aerial, which is electrically balanced, a balance-to-unbalance (balun) transformer and rotating coaxial joint are incorporated in the lower mast bearing. The joint consists of a doubly tapered coaxial line with mercury wetted contacts on the inner and outer conductors at the point of largest diameter. This method of construction avoids variations in coupling when the joint is rotated and ensures a negligible coupling loss. There is no variation with frequency, as would occur with a capacitive coupling and the joint is free from the contact noise which is inevitable with metal-to-metal contacts at very low signal levels. Also, there is no contact wear and the use of a self-aligning lower bearing is facilitated.

Contamination of the mercury due to amalgamation or oil films has no measurable effect on the coupling because the self capacitance of these very thin insulating films is sufficiently high to provide a low impedance path at the frequencies employed.

In order to make maximum use of the directional properties of the aerial, a combined periscope and optical projector are mounted on the roof of the car and mechanically coupled to the rotating aerial.

The operator views a 25° arc of the external scene with a vertical line superimposed, indicating the direction of propagation of the signal received by the aerial. At night, if there is insufficient street lighting an optical projector incorporated in the periscope may be brought into use and a very narrow beam of light momentarily projected on to the building in which a detected receiver is operating.

Panoramic Receiver

Signals radiated from domestic receivers cover a wide frequency spectrum, may have small frequency separation, and are generally of poor frequency stability and low field strength. To resolve these signals a high-gain receiver with narrow i.f. bandwidth is required, but searching for any one particular signal with a manually tuned narrow band receiver is both difficult and laborious.

The narrow-band panoramic receiver developed for the detector overcomes the difficulty by displaying a frequency spectrum of approximately 8 Mc/s, at full sweepwidth, on its cathode-ray screen. The receiver is a triple superheterodyne employing intermediate frequencies of 35 Mc/s, 30 Mc/s and 450 kc/s and having an overall bandwidth of 7 kc/s. The input stage is a modified 14-position television turret tuner employing a low-noise cascode amplifier, frequency changer and stable oscillator. A high-

pass filter in the aerial circuit prevents i.f. breakthrough. The tuner, which has an almost continuous frequency coverage from 110 to 250 Mc/s, is followed by a broadband i.f. amplifier having a centre frequency of 35 Mc/s and an overall bandwidth of 8 Mc/s. A buffer stage separates the 35 Mc/s amplifier from the sweep oscillator. The frequency sweep is achieved by varying the current in an inductor magnetically coupled to the oscillator frequency-determining inductor. This varies the reluctance of the ferrite core, and alters the value of the tuning inductance. By this means a constant percentage frequency sweep is obtained when the centre frequency is varied over a 10 Mc/s range. The amplifier which supplies the biasing current is driven by the horizontal timebase of the c.r. tube. By reducing the drive, the frequency sweep may be reduced from a maximum of 8 Mc/s to zero. This enables the operator to select one signal from a number on the screen and expand it as required, displacing all the other signals from the screen. By reducing the sweep to zero the operator may listen to the signal on headphones. Since the overall bandwidth of the receiver is 7 kc/s and the highest input frequency is 250 Mc/s, an extremely low residual frequency modulation is necessary when zero sweep is required and the h.t. and heater supplies to the frequency modulator drive amplifier are derived from an extremely stable source.

The following stages in the receiver are conven-

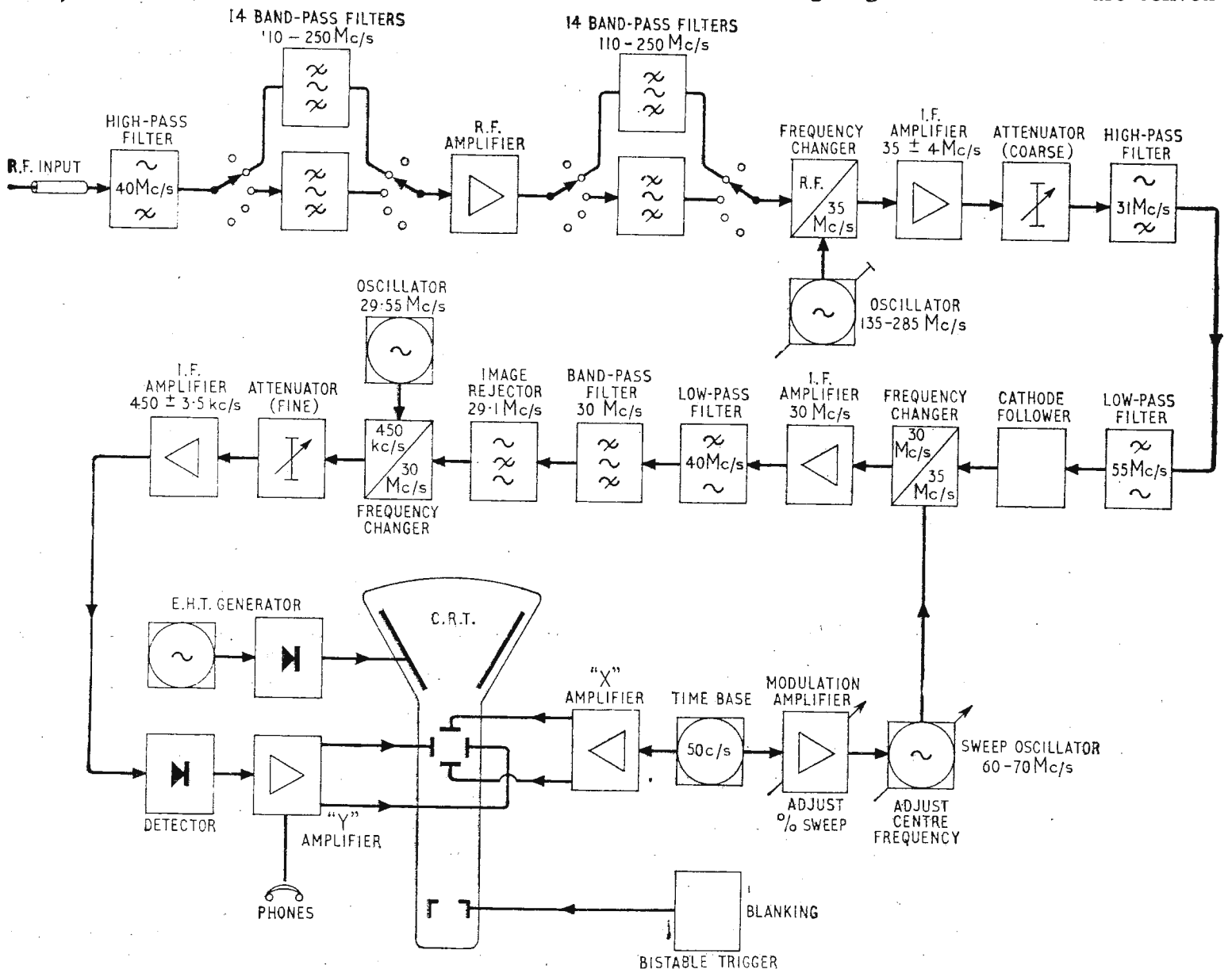

Fig. 1. Block schematic diagram of panoramic receiver.

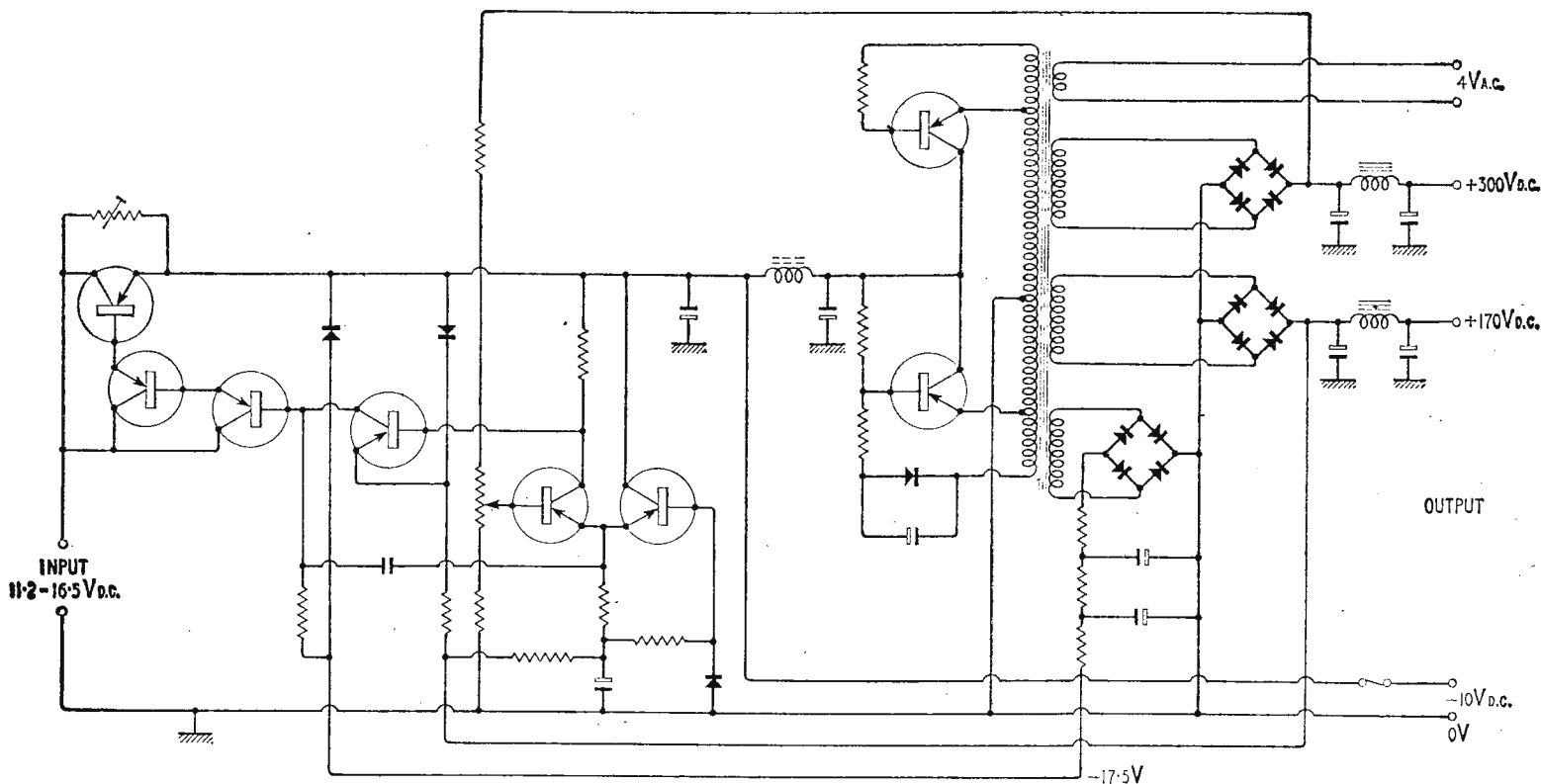

Fig. 2. Circuit of the stabilized power unit which can operate with an input of from 11.2 to 16.5 volts.

tional but extensive filtering and screening have been employed to ensure the complete absence of internally generated spurious signals and spurious responses to external signals of the field strength normally encountered over the entire sound broadcast and v.h.f. range. Fig. 1 shows a block schematic diagram of the receiver.

The detected signals are displayed on a 5-inch c.r. tube employing 3 kV e.h.t. The minimum input signal visible above receiver noise is about 10 dB below $1\mu\text{V}$, giving the detector an overall sensitivity in the region of $1\mu\text{V/m}$. The intensity of the trace on the c.r. tube is dependent on the duration of the applied deflection, a single sweep of the timebase producing a very weak trace. Impulsive interference, being of random frequency and amplitude, does not produce trace brightening by repetition and c.w. signals of low amplitude can easily be seen in the presence of high-amplitude impulsive noise. Thus it is possible to operate the detector in the presence of ignition noise at least 20 dB greater than the wanted signal.

Power Unit

The power supplies are derived from the vehicle battery and wide variations in voltage can occur in service. In order to keep the receiver oscillator drift and residual frequency modulation within acceptable limits it is necessary for the receiver h.t. supplies and some of the heater supplies to be stabilized. Also, the efficiency of the power unit must be high because of the limited capacity of the car battery and generator. These considerations preclude the use of a rotary convertor or carbon pile regulator and similarly neither an electronic valve series stabilizer nor shunt regulator is suitable.

In the power unit described below, the very low voltage drop between emitter and collector of a transistor in the current saturated condition has been exploited, resulting in a regulator and voltage convertor of high efficiency. The high voltage

power supplies are generated by a push-pull self-oscillating transistor inverter, operating at a frequency of 475 c/s and employing a saturated low hysteresis transformer. The square-wave output from the transformer secondaries is rectified by bridge-connected silicon junction rectifiers followed by filters to reduce the output ripple to a few millivolts. A third, unrectified, secondary winding, insulated to 3 kV from earth, provides an isolated and stabilized heater supply for the c.r. tube, which operates with a negative e.h.t. supply connected to the cathode.

It is usual to employ a series stabilizer in the high voltage output of an inverter, owing to the large minimum achievable voltage drop across the control element. This voltage drop is much reduced when a transistor is used as the control element but a protective circuit is necessary to prevent a destructive voltage appearing across the transistor in the event of a momentarily short-circuited load. Furthermore, a separate regulator is required for each output from the convertor and an unrectified output cannot easily be stabilized. These difficulties have been avoided by inserting the voltage control element in the input circuit of the regulator, as shown in Fig. 2 and a low output impedance has been achieved by deriving the error signal for the feedback amplifier from the 300V output. Close control is exercised over those outputs which are not included in the feedback loop because of the very low transformer secondary resistance and leakage reactance and the low resistance ripple filters. The regulated input to the inverter also provides a stable heater supply for critical stages in the receiver.

Currents up to 10A may be handled by the series regulator transistor with a minimum voltage drop of 1.2V and a shunt resistor with a large cooling surface reduces the power dissipated in the transistor to a maximum of 15W, although the maximum dissipation of the regulator may reach 60W when the battery voltage is high. The minimum power

loss in the loaded regulator when the battery voltage is low is 10.5W.

The silicon transistor differential amplifier (long-tailed pair) ensures a low temperature drift and reduces the load on the reference diode.

The low-frequency current gain of the regulator amplifier is about $4\frac{1}{2}$ million and a secondary internal negative feedback path maintains stability by reducing the gain as the frequency increases. Owing to the high transfer impedance of the inverter, which is included in the external feedback loop, the regulator does not entirely remove the ripple in the output and an additional ripple filter is employed.

The power unit can operate with an input range of 11.2 to 16.5V and an ambient temperature range of 0° to 45°C, with a short-term stability of a few millivolts. The total power consumption of the receiver and power unit is about 130W.

The standard car dynamo has been replaced by a three phase self-excited alternator belt—driven by the engine and operating at a maximum speed of 11,000 r.p.m. The current in the rotating field winding of the generator is controlled by a transistor amplified vibrator-type regulator and the stator output is rectified by bridge-connected silicon junction diodes and used to charge two 6V series-connected car batteries of 110 A.h. capacity. With the engine idling, the generator output is sufficient to balance the electrical load and a maximum output of 65A is available at higher speeds.

The car ignition system is fully screened and suppressed and radio interference suppressors have been fitted to the windscreen wipers, petrol pump, heater booster and clock.

Conclusion

The new detection equipment will avoid the difficulties experienced with the earlier system and provide more accurate location of unlicensed receivers, particularly in densely populated areas. Its

"WIRELESS WORLD" INDEX

The Index to Volume 68 (1962) is now available price 1s (postage 3d). Cloth binding cases with index cost 9s, including postage and packing. Our publishers will undertake the binding of readers' issues, the cost being 30s per volume including binding case, index and return postage. Copies should be sent to Associated Iliffe Press Ltd., Binding Department, c/o 4 Iliffe Yard, London, S.E.17, with a note of the sender's name and address. A separate note, confirming despatch, together with remittance should be sent to the Circulation Department, Dorset House, Stamford Street, London, S.E.1.

increased sensitivity permits detection at a greater range, thus reducing the possibility of an unlicensed receiver being switched off because the detector car has been observed. To facilitate the location of a set in a block of flats each of the nine detector cars—there is one for each Post Office Region—is equipped with a portable detector.

The oscillator frequency of a television receiver depends on the channel to which the receiver is tuned, therefore the new television detectors can usually indicate which programme is being viewed. Being able to announce to a householder not only that he has a set working but also which programme he is receiving gives the G.P.O. a psychological advantage.

Acknowledgment is made to the Engineer-in-Chief of the G.P.O. for permission to disclose the information contained in this article.

REFERENCES

1. Bray, W. J., "The detection of television receivers"—*Post Office Electrical Engineers' Journal*—July, 1952, Vol. 45, p. 49.
2. British Standard 905: 1959. "Interference Characteristics and Performance of Radio Receiving Equipment for Aural and Visual Reproduction."

H. F. PREDICTIONS — FEBRUARY

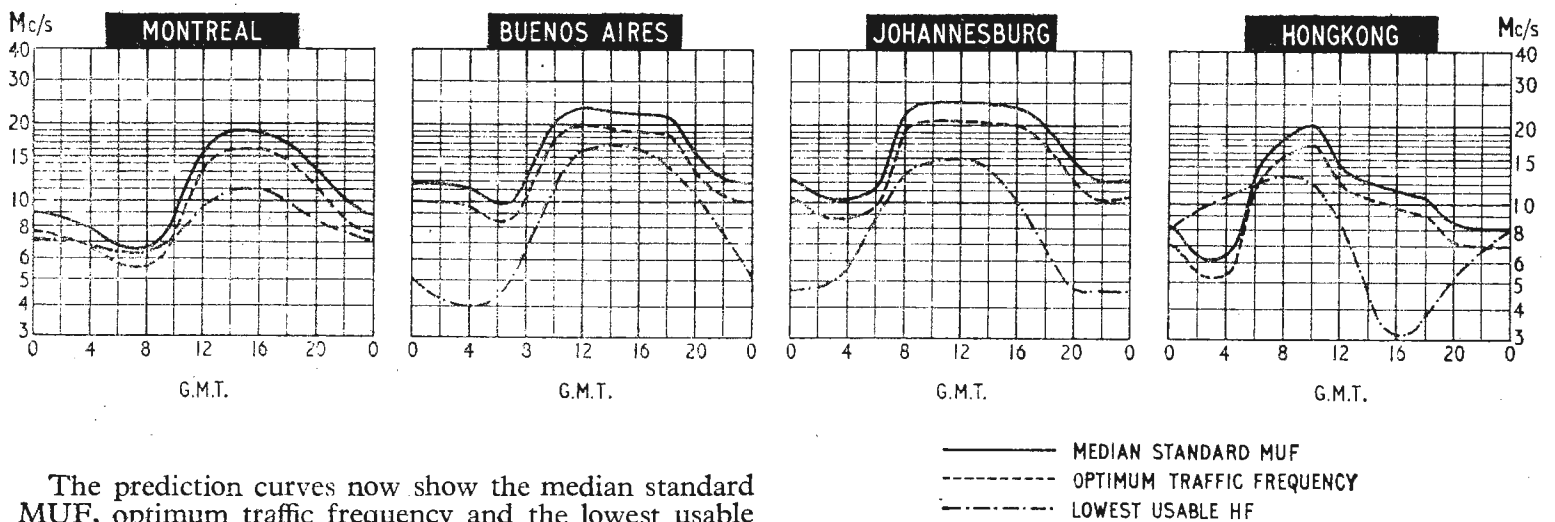

The prediction curves now show the median standard MUF, optimum traffic frequency and the lowest usable high frequency (LUF) for reception in this country. Unlike the MUF, the LUF is closely dependent upon such factors as transmitter power, aerials, local noise level and the type of modulation: it should generally be regarded with more diffidence than the MUF. The LUF curves shown are those drawn by Cable and Wireless,

Ltd., for commercial telegraphy and they serve to give some idea of the period of the day for which communication can be expected. The LUF curve for Montreal takes account of auroral absorption.

Modulated Pulse A.F. Amplifiers

AN ALTERNATIVE APPROACH TO THE DESIGN OF AMPLIFIERS USING SEMICONDUCTORS

By D. R. BIRT

THE present general approach to the design of audio amplifiers with transistors is basically to fit these comparatively new devices into circuits which were evolved for thermionic valves. This article sets out to pose the question "Is this the best solution?" and to suggest an alternative approach.

When transistors are used as linear amplifiers in class A, AB, or B modes, certain deficiencies are encountered. In the first place heat dissipation is much more of a problem in a transistor than in a valve; the day has yet to come when transistors will operate satisfactorily with the collector glowing a dull red! The operating temperature of a transistor has to be kept comparatively low to prevent damage. In the design of transistor circuitry one has always to bear in mind that temperature changes influence certain characteristics of the device. This generally means that the effective resistance of the base circuit has to be kept low. This is not too difficult if transformer coupling is used, but can be a nuisance if RC coupling is envisaged.

Because of the temperature limitation of transistors, class B is a popular mode of operation. This is compatible with the use of transistors in battery-driven portable equipment, where efficiency is all important, for which purpose transistors are very attractive because of their ruggedness and small size and weight. However, even with class B operation, at least 30% of the d.c. input power has to be dissipated in the transistors, with sine-wave drive and resistive load. If very large output powers are required heat dissipation can still be a problem. Furthermore, class B operation has certain disadvantages.

Disadvantages of Class B Operation:—It will be recalled that in class B operation the d.c. supply current fluctuates with the signal level. This is not usually of importance in battery-driven equipment, but in mains-driven equipment it means that the power supply must be well regulated, which adds to its cost and complexity.

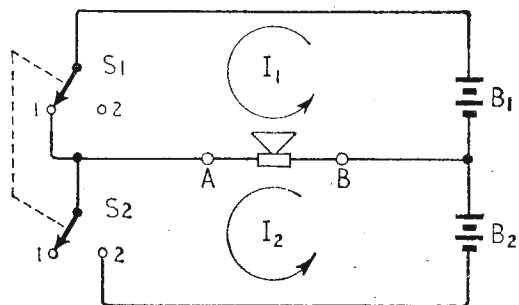

Fig. 1. Basic single-ended push-pull output stage.

With class B operation the matching of the output transistors and signal balance is more critical than is the case with class A or AB operation.

Transistors generally have quite large spreads in their characteristics, and it is obviously desirable to select matched pairs.

A further point is that the circuit operating potentials are critical, particularly the base bias. Here we must recall the changes which occur in transistors with temperature variation.

Finally, we must bear in mind that the performance tends to depend more critically on the load impedance. A factor which has frequently been forgotten in the past, and will no doubt be sometimes forgotten in the future is that in the majority of cases a loudspeaker cannot be regarded as a pure resistance, nor is its impedance anything like constant with frequency. The better class loudspeakers which do have a more constant impedance are often used with crossover networks which put one back in square one as far as impedance variations are concerned!

Negative Feedback:—Features of transistors are first, that their transfer characteristics are not entirely linear, secondly, that they have pentode-like characteristics which places them in the category of constant-current devices. Thus, the output resistance of a transistor amplifier in the absence of feedback is greater than the load resistance, that is, the damping factor is less than unity. It is well known that negative feedback provides an answer to these problems. Any substantial degree of overall feedback precludes the use of inter-stage coupling transformers. The limited bandwidth of transistors means that great care is needed to obtain, in the absence of feedback, a frequency characteristic which will enable the desired amount of feedback to be applied *over the whole audio range* from 20 c/s to 15 kc/s commensurate with an adequate stability margin. Early designs of transistor amplifiers frequently had a loop gain characteristic resembling the response curve of a tuned circuit resonant at 1 kc/s, and although the distortion figure could be encouraging at this frequency, it was very often horrific at 20 c/s.

A great attraction of transistor amplifiers is that the impedances involved often enable standard loudspeakers to be used without recourse to an output transformer. This is not only a technical advantage, but implies a considerable saving in bulk and weight to say nothing of cost!

I would not wish to give the impression that the problems associated with audio amplification by orthodox means cannot be overcome. Indeed recent

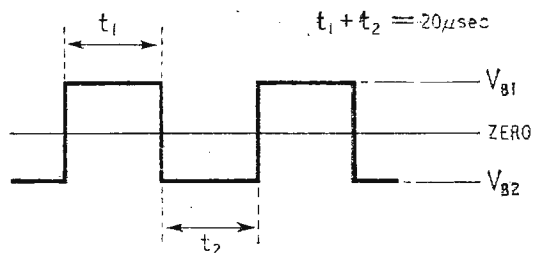

Fig. 2. Waveform across loudspeaker when $t_1=t_2$.

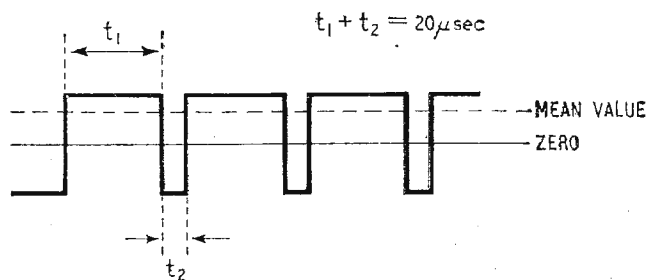

Fig. 3. Waveform across loudspeaker when $t_1 > t_2$.

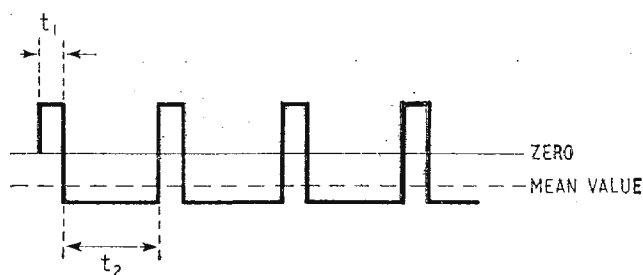

Fig. 4. Waveform across loudspeaker when $t_2 > t_1$.

work indicates that in the field of domestic high quality amplifiers, the transistorised solution is not only possible, but competitive. Technical features which enable this to be so, are the introduction of v.h.f. transistors, overall d.c. coupling, and feedback; and the overall feedback of the order of 40 dB with "π-mode" operation (constant supply current) enables the power supply problems and cross over distortion associated with class B operation to be overcome whilst retaining high efficiency of maximum output.

So much then for the situation where transistors are employed as linear amplifiers.

Alternative approach:—But suppose we attack this from a different angle. Suppose we take a look at the characteristics of a transistor, and see where its potentialities lie. One way in which a transistor functions very well, better in fact than a thermionic valve, is as a switch. It functions well as a switch because its forward resistance is very low. Put in another way, its knee voltage is very low: a hundred millivolts or so compared to 30-100 volts for a thermionic valve. Fair enough, now how do we make an amplifier using switches? This may sound a tall order, but in fact it is very simple. By the use of well-known pulse techniques, we can obtain a pulse waveform at ultrasonic frequency upon which we can impress audio frequency information as pulse duration modulation. The pulse waveform can be readily amplified by semiconductor devices operating as switches, i.e. operating either fully conducting or turned off. Finally, the audio information is recovered by means of a low-pass filter.

To explain this a little more fully, I think it is easier to start at the loudspeaker and work backwards. Fig. 1 shows one possible output circuit, which will serve to explain how the system operates. This is a single-ended push-pull configuration in which there are two current paths I_1 and I_2 . The current I_1 is supplied by the battery B_1 , and when S1 is closed (position 1) this current flows through the loudspeaker in the direction AB. We shall say that a current in this direction causes the cone to move outwards.

Note that the switches S1 and S2 are ganged and that when S1 is closed, S2 is open and *vice versa*. Now let us move the switches to position 2 so that S2 is closed, but S1 is now open. Current I_2 now flows from the battery B_2 through the loudspeaker, but in the direction BA, so that the cone now moves inwards. So we have the conditions:—

Switches position 1, cone moves outwards.

Switches position 2, cone moves inwards.

Now let us operate the switch very rapidly, say at a frequency of 50 kc/s, and arrange that it spends an equal time in position 1 as in position 2. Let us call these times t_1 and t_2 respectively. The voltage waveform across the loudspeaker will be that shown in Fig. 2; it is a 50 kc/s square wave, with unity mark-to-space ratio.

At this stage let us suppose that the loudspeaker we are using has a heavy cone, and cannot respond to frequencies above, say, 5 kc/s. It is therefore a low-pass filter, and will not respond to the 50 kc/s signal applied to its terminals. Since the waveform of Fig. 2 has a mean value of zero, the mean current flowing will be zero, and the cone will remain undeflected.

Now let us continue switching at 50 kc/s but arrange the switch to stay longer in position 1 than position 2. This condition is shown in Fig. 3. Here the mean voltage is no longer zero but assumes a positive value. Fig. 4 shows the conditions when $t_2 > t_1$ where the mean voltage is negative.

We saw earlier that when the switch was permanently in position 1 the cone moved outwards and we can now see that when the switch spends *most* of the time in position 1 the cone moves outwards. Similarly, if the switch spends most of the time in position 2, the cone moves inwards. The extent of the cone movement depends on the ratio of the times t_1 and t_2 , i.e. upon the percentage deviation

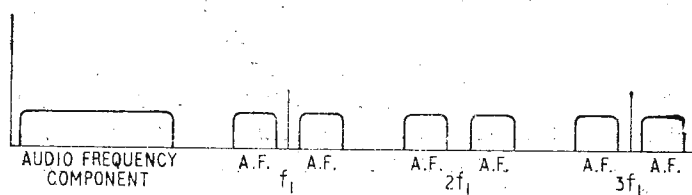

Fig. 5. Main components (not to scale) of a pulse modulated at audio frequencies where f_1 is the pulse repetition frequency (50kc/s).

of the mark:space ratio from unity. The relationship between cone movement and mark:space ratio is entirely linear, so that provided that we can vary the square wave mark:space ratio linearly with respect to the applied audio signal, we have the basis of a linear amplifier.

Those who have a flair for mathematics may care

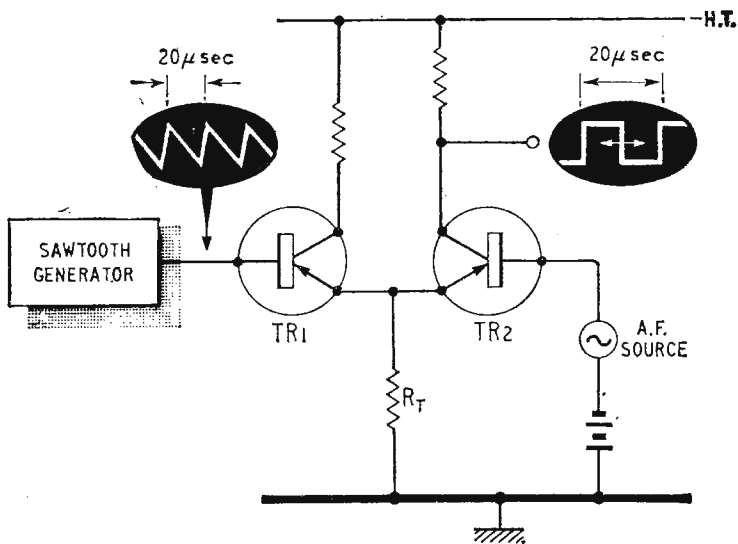

Fig. 6. Pulse modulator.

to look at this another way, and perform a Fourier analysis of the modulated square wave or duration-modulated pulse which is another name for the same thing. Such analysis yields the spectrum shown in Fig. 5. There are actually additional components to those shown, given by a Bessel function. These have been omitted for clarity but will be referred to later.

Notice several interesting points about this circuit:—

1. Provided the switches are efficient, negligible power is dissipated in them.
2. Since one or other switch contact is always closed, the output source resistance is substantially zero.
3. No harmonic distortion is introduced.

In the simple arrangement shown in Fig. 1 there will, of course, be a continuous h.f. power dissipation in the loudspeaker speech coil, due to the fundamental pulse repetition frequency (50 kc/s) and harmonics associated with the step function. However, we can avoid this by inserting a low-pass filter instead of using the cone mass to provide low-pass filter action. The ultimate efficiency depends largely on the losses incurred in the filter. If the filter losses were zero, then the theoretical efficiency would approach 100%. In practice efficiency comparable to that obtained from a class B stage can easily be realized.

Transistors can readily be used for the switches, so also can silicon controlled rectifiers, provided their turn-on and turn-off times are sufficiently short. With these latter devices power outputs of several hundred watts can be envisaged. Four-layer p-n-p-n avalanche diodes also offer attractive possibilities.

However, before beginning too many pipe dreams of kilowatts, perhaps we should consider some methods of producing a width-modulated pulse.

Pulse Modulators:—The modulator is required to convert amplitude differences to time differences. The primary waveform is therefore one which has a linear amplitude to time relationship, i.e. a sawtooth. By feeding an ultrasonic sawtooth waveform, plus an audio signal into a "slicer," or voltage coincidence detector, the required waveform may be produced. This will be explained with reference to the diagram Fig. 6 where a long-tailed pair co-

incidence detector is shown by way of example. The operation of the circuit is as follows. At the start of the sawtooth run-down TR1 base is negative, so that TR1 conducts heavily. TR1 emitter current flows in the "tail" resistance R_T and develops a negative voltage on the emitter of TR2 which is by choice more negative than the base of TR2. TR2 is thus cut off and its collector voltage is therefore equal to the supply voltage. The circuit remains in this condition whilst the sawtooth run-down continues, until the point is reached where the base voltages of the two transistors are substantially equal. At this time TR2 commences to conduct, and its collector potential falls. For a short time, both transistors conduct, but continuation of the sawtooth run-down causes TR1 to cut off, whence TR2 conducts heavily. The circuit remains in this condition until the end of the run-down when with the flyback of the sawtooth generator, the cycle recommences. The timing of the voltage transition of the output waveform depends on the instantaneous value of the voltage at the base of TR2, that is, upon the audio input signal. The battery shown in Fig. 6 provides bias equal to the mean value of the sawtooth, so that in the absence of audio modulation the mark:space ratio of the output square wave is unity.

Transfer Characteristic:—A very important point is that the sawtooth waveform represents the transfer characteristic of the amplifier. It follows that for good linearity this waveform must be linear. In practice a sawtooth with curvature causing rather less than 0.25% harmonic distortion for 50% modulation is readily provided by generators of the Miller or the bootstrap families.

What is perhaps even more interesting is that almost any desired shape of transfer characteristic can be provided by appropriate shaping of the sawtooth by means of RC networks. For example a logarithmic transfer characteristic is very easily provided. We shall consider this in more detail later.

Coincidence Detectors:—There are many types of coincidence detector which can readily be used, and the long-tailed pair is but one example. Other possible types are a double diode clipper, triggered blocking oscillator or Multiar, or a saturable transformer employing a square-loop ferrite core.

Drive Requirements:—We have now seen how a train of width modulated pulses can be generated, and considered one possible output stage configuration. It is now appropriate to consider the requirements of the intermediate stages. Before this is possible it is necessary to consider one or two further points about the output stage.

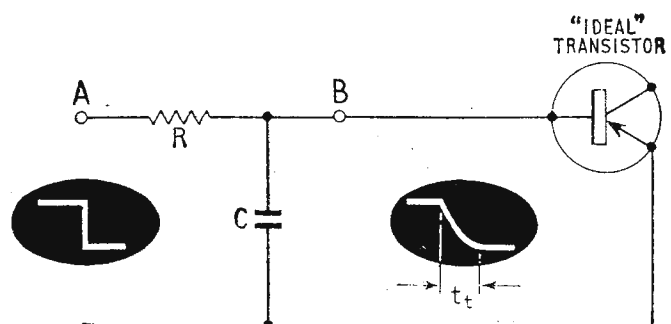

Fig. 7. Equivalent circuit of transistor.

When looking at Fig. 1, we saw that the dissipation in the switches was very small, because the switch was either closed, and thus there was substantially no voltage across it, or it was open and there was no current flowing. Transistors, however, are not perfect switches, because they do take time to turn off, and during this turn-off time there exist both a current in the transistor and voltage across it. To minimize the inherent power loss, we must choose a drive waveform which gives the minimum possible turn-off time. Now let us spend a moment on this point.

Fig. 7 shows the approximate equivalent circuit of the transistor as seen by the driver stage. For conduction to occur the voltage at point B must be negative. The transistor ceases to conduct when the voltage at point B is approximately zero, and remains non-conducting if the voltage at this point becomes positive with respect to the emitter. Unfortunately, there are built into the transistor two components, the base resistance R and the input capacitance C . Thus if we apply a rapid positive-going voltage step to the base terminal A, nothing happens until the capacitor C has discharged through the resistance R . Only then after the time interval t_t will the transistor be turned off. During the period t_t there will be at some time insufficient base current to keep the transistor bottomed, and there will exist both current in the transistor, and appreciable voltage across it.

Clearly the way to discharge the capacitor C as rapidly as possible is to encourage a high current to flow out of it. This can be achieved by connecting the point A to a low-impedance positive source. We have to be careful because there is a limit to the positive voltage which we can allow to build up across the capacitor C . Once the capacitor C is discharged, we can hold the transistor safely off with only a very small positive voltage. Just enough in fact to allow for collector leakage current. The desired drive waveform is therefore shown in Fig. 8.

To recapitulate, we have seen that with transistors there is always some delay in the turn-off operation. For minimum losses this delay must be as small as possible. We achieve this in two ways, first by selecting a transistor in which R and C are small, secondly by ensuring that the optimum drive waveform is provided from a low-impedance source.

Regenerative Output Stage.—It is also necessary to make sure that the turn-off delay does not allow both transistors to conduct together, as obviously the losses would then be very high. An effective way of ensuring that this cannot happen is to arrange for the output transistor which turns off, to turn on the opposite transistor. This is achieved with the regenerative circuit configuration, well known for its use in inverter applications, shown in Fig. 9.

The free-running frequency of the circuit is made very low (a few cycles) by using a centre-tapped choke of large inductance. At 50 kc/s, therefore the circuit functions virtually as a bi-stable multivibrator. If we suppose that TR1 is conducting, and we wish to switch the circuit to the alternative state where TR2 conducts, then this is achieved by applying a positive trigger pulse to the base of TR1 (as in Fig. 8). TR1 therefore turns off, and its collector voltage rises to twice the supply voltage. Since the collector of TR1 is linked to the base of

TR2, TR2 is brought into conduction. When in conduction TR2 collector is virtually at earth potential, and this prevents TR1 from conducting. To revert the circuit to its original state, a positive pulse is fed into the base of TR2. To prevent power loss in the base of collector resistors, a separate winding can be used to supply the base drive.

For this type of circuit, which has many attractions, the drive waveform is not the square wave with variable mark:space ratio which we obtained

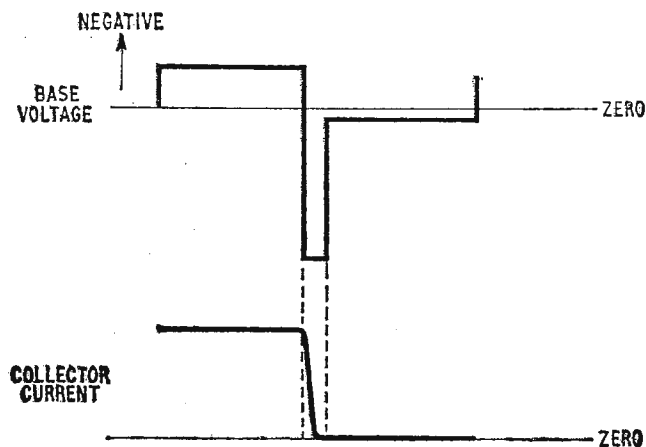

Fig. 8. Optimum drive waveform.

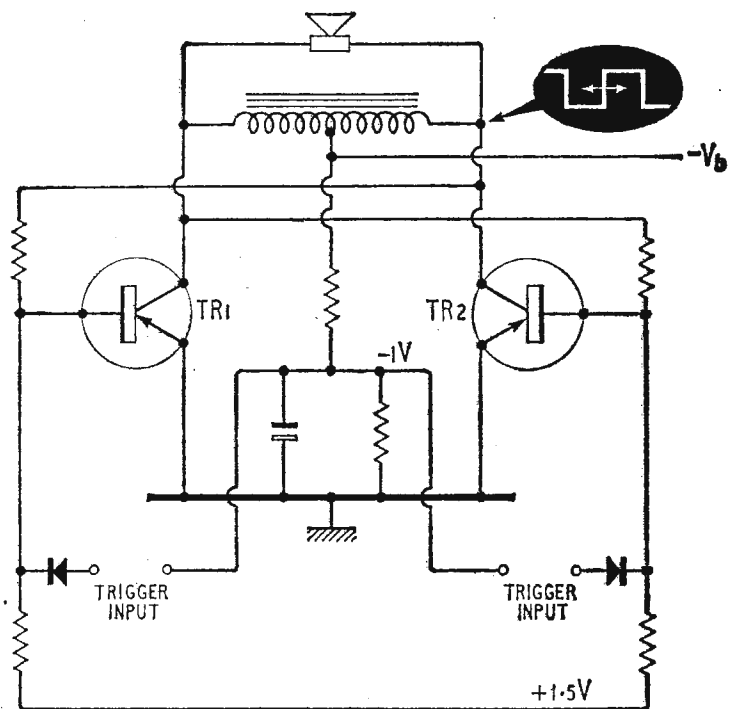
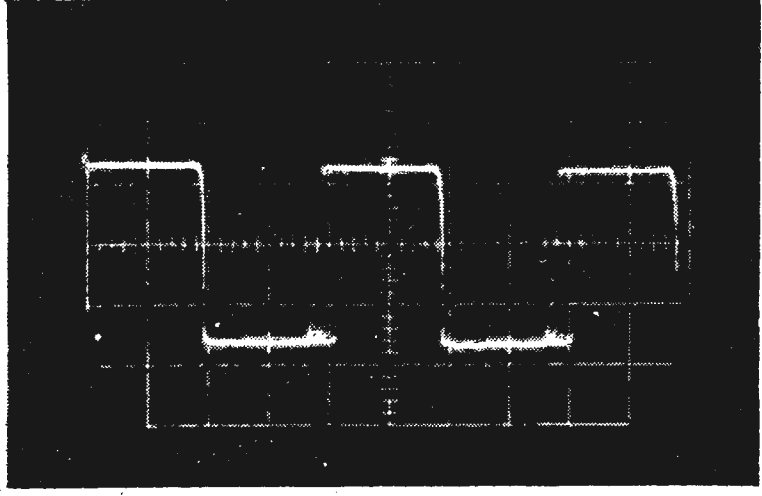
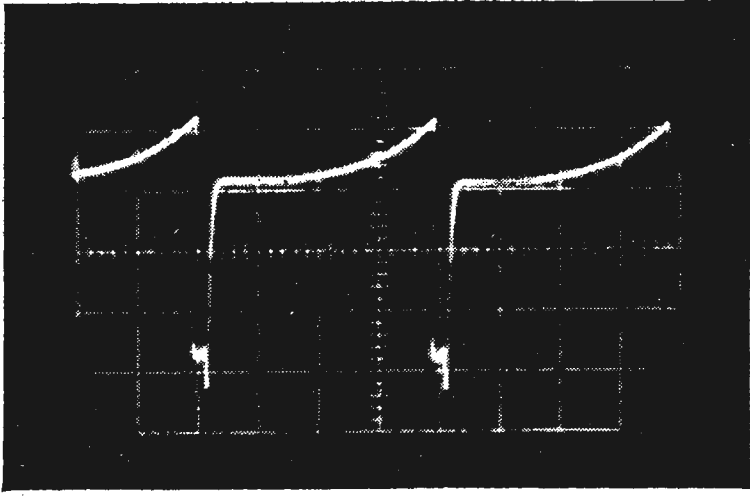

Fig. 9. Regenerative output stage.

from the modulator. Instead two pulse trains are required, one fixed in repetition frequency (e.g., 50 kc/s) and corresponding to the fixed edge of the square wave. Interlaced with these pulses we require a train of position-modulated pulses which correspond to the time-modulated transition of the square wave. The pulses do not have to be rectangular, but will yield a faster turn-off time per peak volt of amplitude if they are rectangular.

These trigger pulses are readily obtained from the duration-modulated pulse output of the modulator, by differentiation. This is shown in Fig. 11. It is then only necessary to invert the negative going pulses and do a bit of shaping to obtain the waveform of Fig. 10. The resultant waveform at the



Oscillograms of experimental circuits. Left, blocking oscillator output and, right, modulator output at 1kc/s. Time base speed 5 μ sec/cm.

bases of the transistors of Fig. 9 is then the optimum waveform of Fig. 8!

It is worth mentioning at this point that a pulse-position-modulated waveform is easier to handle than the duration-modulated pulse with fixed voltage boundaries, because it contains no audio-frequency components. Thus the design of coupling networks is made easier, because only a reduced frequency range has to be handled.

Non-regenerative Output Stages.—If a regenerative output stage is not used, then a proportion of the direct output from the modulator must be added to obtain the base waveform of Fig. 8. It may also be necessary to incorporate a simple delay network to delay only the turning on action of the output transistors by a time at least equal to the circuit turn-off time. This is to avoid both output transistors being "on" together. The delay network may consist of a series resistance in the base, which in conjunction with the input capacity provides delay. The action is made one-way by shunting the resistance with a diode. Alternatively, combinations of inductance, resistance and a diode may be used.

Complete Amplifier.—We have now collected, and examined enough bricks to build a complete amplifier, at least in block form. Fig. 12 shows one possible form for stereo operation. This is to emphasize that it is not necessary to duplicate everything. It is also interesting to note that it is possible to control the gain of both (or any number of) channels by varying the amplitude of the sawtooth fed in parallel to the separate long-tailed pairs. This has the effect of varying the depth of modulation. This does not require ganged potentiometers, and the gain and transfer characteristic of both channels will always be identical.

Some preliminary experiments have been made with an arrangement of this form using OC23 transistors in a circuit similar to that of Fig. 9, as being an easy starting point. To date, the circuit has functioned with a collector dissipation per transistor of some 50 mW. An output power of a few watts has been obtained, but it is hoped to improve considerably on these figures.

This form of circuit has the disadvantage of requiring a centre-tapped choke, which must have a large reactance and be clear of saturation at the lowest audio frequency. A single-ended push-pull

arrangement would not require such a component, and it is thought that a pair of complementary transistors (n-p-n+p-n-p) would offer some attractive advantages. It is worth noting that two such transistors do not have to be matched for this application.

Modes of Operation.—In the simple case where no electrical low-pass filter is used, it has already been seen that there will be continuous h.f. power dissipation in the load. If we were to use 100% modulation, the efficiency $P_{out} (a.f.) / P_{in} (d.c.)$ would be 50%, and the d.c. power taken by the output stage would remain constant. This is analogous to class A operation.

If we insert a low-pass filter to prevent a continuous power dissipation in the loudspeaker, which would frequently be unacceptable, then the efficiency becomes higher, because the standing power loss has been removed. However, higher efficiency implies that the d.c. power drawn by the circuit must fluctuate as in a class B stage. In mains-operated equipment this may be some disadvantage, as it calls for a well-regulated power supply. However, this difficulty can be overcome in another way. If in the output leads we place not just a low-pass filter, but a crossover network, and feed the low-frequency output to the loudspeaker, and the high-frequency output to a resistor of equal resistance to the loudspeaker, then the load seen by the output stage is resistive at all frequencies. If we choose the crossover frequency between the top end of the audio band and the pulse repetition frequency, then there will be negligible h.f. power dissipation in the loudspeaker, but this power will be transferred to the terminating resistor of the high-pass section. The current taken by the output stage will however be constant, so that there is now no need to provide a regulated d.c. supply. It is only necessary to mount somewhere a wire-wound resistor (which will get rather hot!).

Distortion.—Though in theory pulse duration modulation (p.d.m.) and demodulation is a linear process, it is possible for distortion of the pulse to occur, which will give rise to harmonic and inter-modulation distortion of the audio signal.

For example, if the output stage drive waveform is not correct, it is possible for the turn-off time to vary with the mark:space ratio. This timing error, will give rise to distortion. Apart from timing errors,

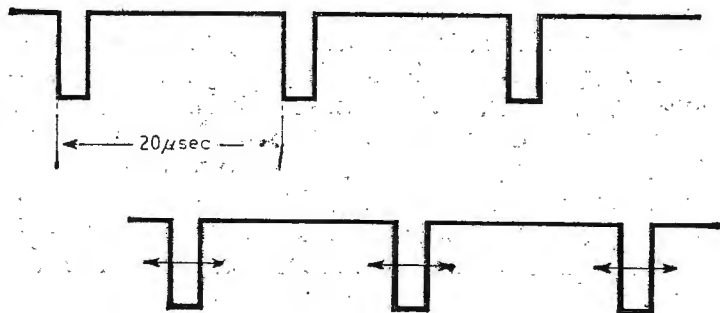

Fig. 10. Triggering waveforms for regenerative output stage.

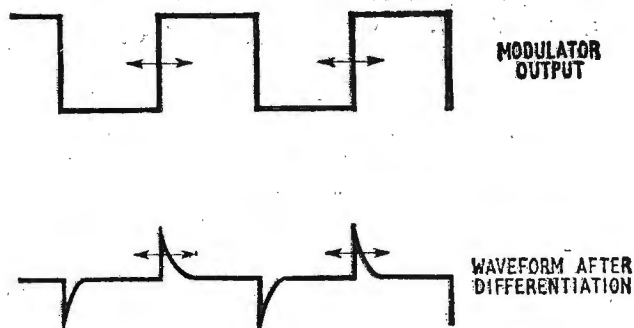

Fig. 11. Conversion from pulse duration modulation to pulse position modulation.

amplitude errors can also give rise to distortion, for the system is only linear if the pulse amplitude remains constant. The most likely cause of amplitude distortion is variable amplitude overshoots on the output waveform as a result of stored energy in the inductive elements of the circuit, and in the circuit of Fig. 9, it is in fact necessary to connect a diode from the collector of each transistor to earth to remove the overshoots.

If the output stage is badly designed so that there is insufficient base current to hold the transistors bottomed at high modulation levels, then distortion will again be introduced by non-constant amplitude arising in this case from the equivalent of dirty switch contacts! However, these sources of harmonic distortion can be designed out of the circuit.

Non-harmonic Distortion:—Inherently there arises distortion which is not harmonic. The missing frequencies from Fig. 5 are difference frequencies

between harmonics of the audio frequencies, and the pulse repetition frequency. These become zero each time a harmonic of the audio frequency coincides exactly with the pulse repetition frequency: hence the Bessel function. When not exactly coincident, the amplitude of the beat note depends on the depth of modulation. That is for minimum beat distortion the depth of modulation should be low. By choice of a high pulse repetition frequency, the major beat frequencies can be placed outside the audio band. An analysis of pulse duration modulation is given in reference 1 and the following table gives an idea of the magnitude of the distortion:—

Mod. index (%)	Beat Products	
	$\omega_p - 2\omega_A$	$\omega_p - 3\omega_A$
5	-28 dB	-60 dB
10	-22 dB	-48 dB
20	-16 dB	-36 dB

where ω_p = pulse repetition frequency. ω_A = audio frequency.

The amplitude of the product $\omega_p - 2\omega_A$ follows a square law relationship to the modulation index; and the amplitude of the $\omega_p - 3\omega_A$ product, a cubic law. Modulation index in this context is defined as the percentage deviation of the mark: space ratio from unity. That is a 50:50 ratio gives a modulation index of zero, and a 60:40 ratio gives a modulation index of 20%.

Precisely the same kind of distortion occurs in tape recorders due to the h.f. bias, but it is known that very high quality reproduction can be obtained from this medium. In a p.d.m. amplifier, however, it seems not impossible that the distortion could be reduced, by recovering the audio signal from the output of the modulator, and re-applying it to the input to provide negative feedback.

Motional Feedback.—While on the topic of distortion and feedback, an interesting possibility exists for the application of motional feedback. This is a form of feedback which we hear about from time to time, but which never seems to have caught on much with loudspeakers, though it is used with disc cutters. Basically the system is to derive a voltage which is

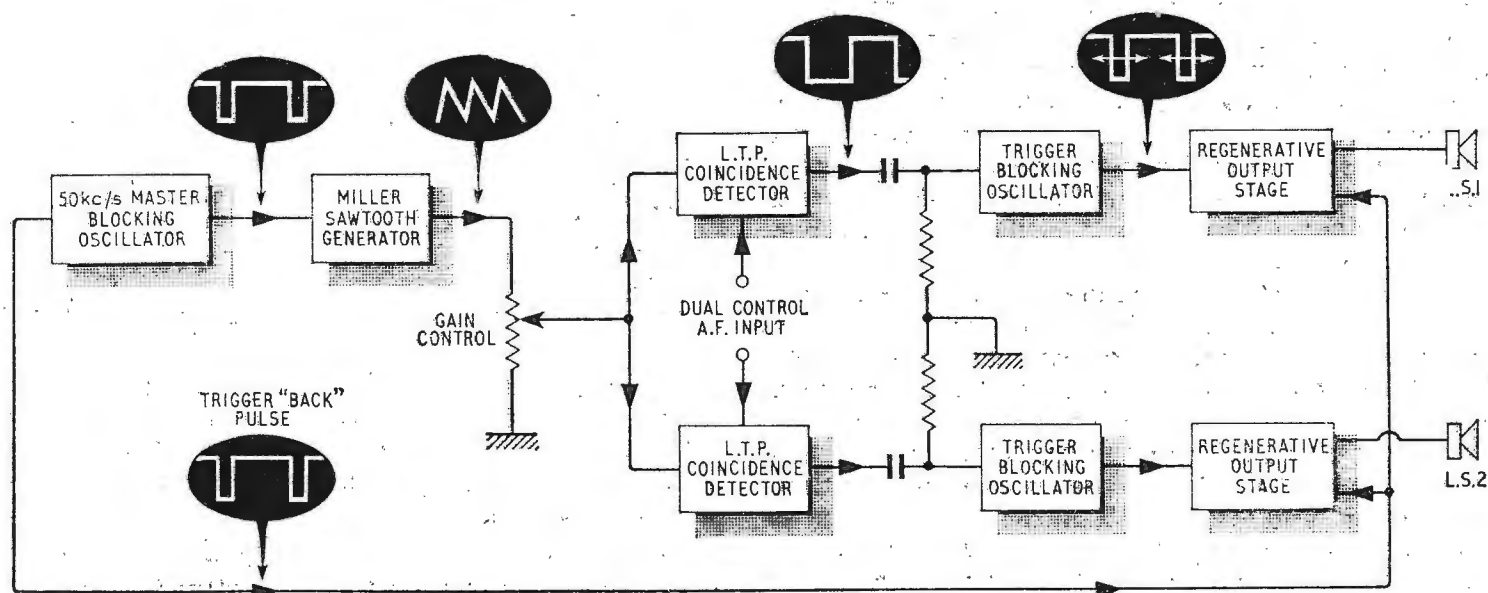

Fig. 12. Block diagram of complete stereo amplifier.

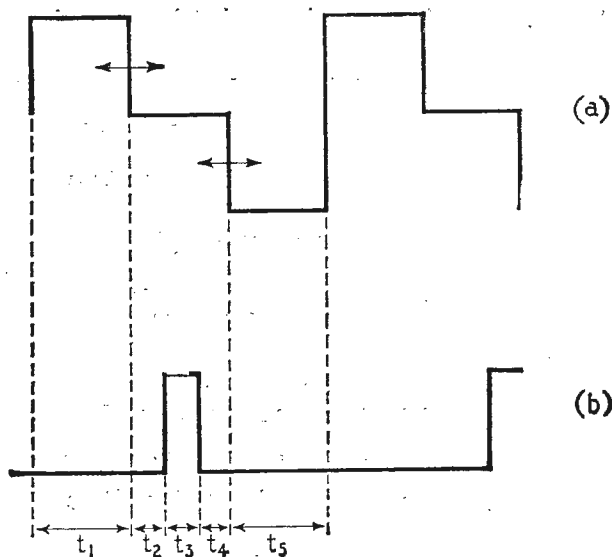

Fig. 13. (a) Suggested output waveform to facilitate motional feedback. (b) Gating pulse.

proportional to the cone velocity, or amplitude of movement, and apply it as feedback. In this way the cone movement can be very precisely controlled, and non-linearities due to the suspension can be very greatly reduced. Thus, provided the cone acts as a rigid piston, the sound pressure wave can be made to correspond very closely to the audio signal. Since even foamed polystyrene cones break up at higher frequencies, motional feedback is only useful at low frequencies. However, this is where non-linearity distortion occurs with moving-coil loudspeakers, because of the larger amplitude of cone movement.

The required feedback voltage exists as the voice-coil back e.m.f., if only we could get at it. One method of obtaining the back e.m.f. is to use a bridge circuit in which the loudspeaker is used in conjunction with a dummy loudspeaker, which has the same or a scaled electrical impedance.

In the author's experience, the impedance of loudspeakers which have an aluminium coil former is extremely complex, and is subject to some variation with cone displacement. Thus it is very difficult to balance accurately the bridge and to obtain the true back e.m.f.

A further difficulty occurs in conventional amplifiers in that the low-frequency phase shift leads to stability problems when a reasonable amount of feedback is attempted. However, pulse techniques would seem to offer a possible solution to both these problems. In the first place a p.d.m. amplifier can readily operate down to d.c. if required, thus eliminating low-frequency phase shift. Secondly, it is suggested that by a simple modification to the output waveform we have so far considered, combined with a sampling operation, it should be possible to obtain the back e.m.f. The method is illustrated in Fig. 13, where the two "halves" of the square wave have been so to speak, moved apart. Thus the time intervals t_1 and t_5 vary as before in accordance with the audio modulation. However, the time interval made up of $t_2 + t_3 + t_4$ is fixed, and it will be seen that during this interval neither of the output transistors conducts, and thus the loudspeaker terminals are open-circuited. The voltage present at this time is therefore the speech-coil back e.m.f. which is proportional to the coil velocity. If we now connect to the speaker terminals a gated amplifier which is brought into operation by the gating pulse shown in Fig. 13(b), we shall obtain at the output a pulse of

constant width t_3 but of amplitude dependent upon the back e.m.f. It is then necessary to derive a feedback voltage which is directly proportional to the pulse amplitude. One must remember that two things happen to this pulse when modulation is present. First, successive time intervals between pulses vary in accordance with the audio modulation as in a pulse-counting f.m. discriminator. Secondly, its amplitude varies in accordance with the back e.m.f.

If we simply pass the pulse through a RC network, we shall obtain an a.f. feedback voltage due to both causes, whereas ideally we require a voltage which is purely a function of the back e.m.f., i.e., pulse amplitude.

However, not to worry, if we make the output from the gated amplifier charge a capacitor up to the peak value of the pulse, retain the charge and add it to the audio input signal in the sense which provides negative feedback, all is well. Provided we discharge the capacitor the next time the coincidence detector operates (which will be at a time determined by the charge on the capacitor and the a.f. voltage) and then recharge it to the peak amplitude of the next gated amplifier pulse, then the feedback voltage contains only information about the back e.m.f.

It is necessary to include the time interval t_2 to allow the voltage pulse associated with the energy stored in the inductance of the loudspeaker to decay, before the gated amplifier opens. It is clearly an advantage if not a necessity to choose a loudspeaker with low inductance. The interval t_1 allows a margin of safety before the second transistor turns on. The gating pulse generator can conveniently be triggered from the first negative "edge," and the second transistor can be turned on by a pulse derived from the back edge of the gating pulse.

At the moment, the author has not had the opportunity of trying this arrangement, so the idea remains in the hypothesis stage; but no reason can be seen why it should not be made to work.

Linearity Correction. There still remains a bit more to be said about linearity, for it was seen earlier that the system transfer characteristic was governed by the shape of the "sawtooth" fed to the modulator. By the use of so called "linearity correction" networks as used in television timebases, we can "mangle" the sawtooth to almost any required degree, and thus obtain the most complex transfer characteristic. By appropriate choice of the shape it is possible to cancel distortion produced in other parts of the system. The linearity networks may consist of passive elements of capacitance, resistance and inductance in various combinations, and offer far more scope than conventional gamma correctors, which rely on the characteristic of a diode or combinations of such characteristics.

One can also make the transfer characteristic a function of frequency to compensate for distortion, which is a function of frequency, by the method shown in Fig. 14. Here the modulator is preceded by a bass-lift filter. Thus the depth of modulation increases at lower frequencies. Since the transfer characteristic has in this example been chosen to have a linear centre position, but sharp curvature at the extremities, high frequencies at low modula-

(Continued on page 83)

MINIATURE CIRCUIT BREAKERS AND CUT-OUTS



"Belling-Lee SECUREX"

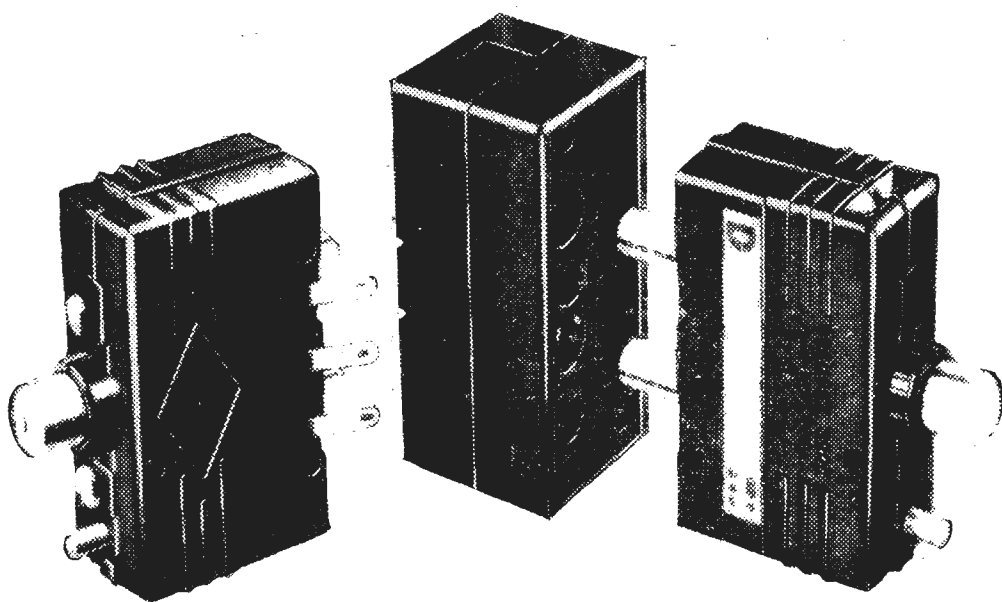

Precision, trip-free safety devices for electrical and electronic equipment, local circuits in laboratories, workshops, etc. —

- Ratings: 40mA to 20A at 275V.
- Max. breaking capacity: 750A.
- Surge resistance excels any fuse.
- Manually re-set without servicing.
- Fixed or plug-in mounting.
- Auxiliary signalling contacts.
- Temperature compensated and tropical models available.

— combining the functions of a switch, indicator, and delay fuse in a single unit occupying only 1.6 □" panel space.

Most "Belling-Lee" products are covered by patents or registered designs or applications

BELLING & LEE LTD
GREAT CAMBRIDGE RD., ENFIELD, MIDDX., ENGLAND

Telephone: Enfield 5393 • Telegrams: Radiobel Enfield

"BELLING-LEE" NOTES

No. 45 of a series:

The UHF Tests

In Southend recently we managed to obtain pictures of fair quality from the B.B.C. experimental transmission on channel 44 (Band V), using a "Metropolitan" set-top aerial standing on the receiver, which was situated in a first floor room. The distance from the Crystal Palace transmitter is about 33 miles, so this was not bad going considering the present moderate e.r.p. of 160 kW.

Other reports of long range reception, using **outdoor** aerials, are becoming commonplace, and it might seem as if the pundits were unduly pessimistic in their forecasts. However, it is better to err initially on the cautious side, for people do not usually complain if they obtain better results than they were led to expect, and it is, of course, too early yet to begin to formulate an overall pattern of coverage.

Although first results with black-and-white transmissions are encouraging, we cannot over-emphasise the fact that this gives no real indication of what to expect from colour television. Receiver 'noise' is slightly more of a problem with the latter, inasmuch as the resulting haze is coloured. Man-made interference produces a similar effect or, if it is very intense, a pattern of black spots (on negative modulation) which are surrounded by colour fringes and look something like confetti. Phase delays introduced with reflected signals may, if slight, raise or lower the colour luminescence level, but if the delay is sufficient to produce a separate image, the "ghost" is coloured. All these effects are more disturbing to the eye, and additionally, extreme phase delays may affect the sound and give rise to an audible buzz due to the displaced carrier punching through into the FM sound channel.

At the moment, therefore, we still counsel either wait and see or, if you are putting up an aerial, let it be of the very best type to avoid possibly having to change it for something better later. We must, too, issue this reminder, that although the u.h.f. aerials we are supplying now will also be satisfactory for reception of the additional test transmissions which the B.B.C. plans to radiate on channel 34 shortly, they will not be correct for the first service transmissions, which are likely to use channels in the lower half of Band IV.

Advertisement of

BELLING & LEE LTD.

Great Cambridge Rd., Enfield, Middx.



by

SUFLEX
LONDON

SUFLEX LIMITED · BILTON HOUSE

· UXBRIDGE RD · W5 · Tel: EALING 7733

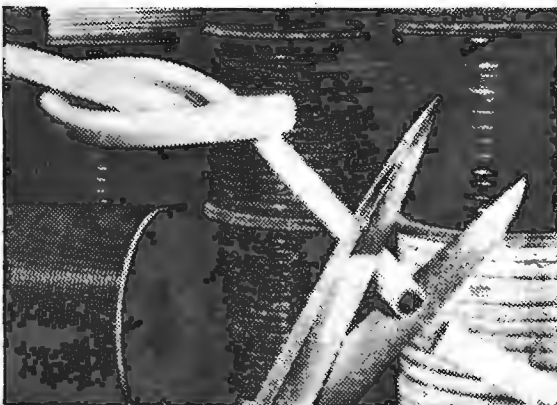

Suflex Sleeving is available in a variety of types for varying applications and all are notable for their quality and reliability in use.

They comprise Peribraid Silver Glass Sleeving, Coloured Glass Sleeving, Silicone Glass Sleeving, Periglas P.V.C. Coated Glass Sleeving, Varnished Glass Sleeving, Varnished Terylene Sleeving, Varnished Cotton and Rayon Sleeving. All are supplied in a wide range of bores and colours. Detailed Leaflets and prices on request.

tion will be amplified linearly but low frequencies which cause heavy modulation will be "distorted" in the required manner. To maintain a flat overall frequency characteristic, a bass-cut filter is included in the output. Although this system offers more scope than existing methods of gamma correction, it will not be possible in every case to cancel distortion entirely in this way.

Other Applications: It is thought that this form of "gamma corrector" may have other applications, possibly in the sphere of electronic musical instruments, where it could be used for tone forming. The sawtooth shape may be chosen to provide the harmonic structure required for a particular stop.

Tape Recording: It has been suggested that in the conventional method of recording using h.f. bias, the resulting "pattern" on the tape resembles the p.d.m. wave train, we have been considering. It would therefore be of some interest to apply such a waveform as a current in standard recording head, and compare the recording process with that of the classical method. The writer again regrets that time has not been available to perform any experiments of this nature, but perhaps some reader would like to oblige?

Taking Stock

Having digressed somewhat from the original theme of audio amplification using pulse techniques, may we return to take stock of the situation? It has been seen that pulse techniques offer an alternative method of audio amplification to the established method. A little searching has revealed that this idea is not new, and was in fact proposed in a patent specification due to B. D. Bedford in 1930 (ref. 2). What a lot of forward thinking ideas were evolved at that time! Thyratrons were proposed, using the series choke, parallel capacitor triggering method now popular in thyristor inverters. Clearly the thyratrons of the 1930's imposed severe frequency limitations. Thermionic valves are not very suitable, because of their relatively high impedance. However, it seems to the writer that with the advent of transistors and thyristors we need to take a fresh look at this technique. Clearly a very great deal of circuit development work needs to be done in order to evaluate the best techniques. This will facilitate an appraisal of the system and give a guide to the sphere in which it is most likely to be competitive. At the moment, one can visualize applications from high-power public address systems, using thyristors, to specialist domestic audio systems probably involving transistors, possibly using refinements of motional feedback. At the present time a hybrid solution may be attractive, where valves are used for the pulse generating and modulating stages, and transistors for the output stage. The advantages offered by double valves, of which there is no semiconductor counterpart, could thus be utilized.

It is realized that much of what has been written is only in the "idea" stage, but the writer feels that, in order to stimulate interest in the subject, it is preferable to bring pulse modulation into the light at this early stage, rather than to wait until all the answers are known. However, certain advantages are known. First, the performance of such an amplifier is not dependent upon transistor characteristics; thus matching is not required, and the

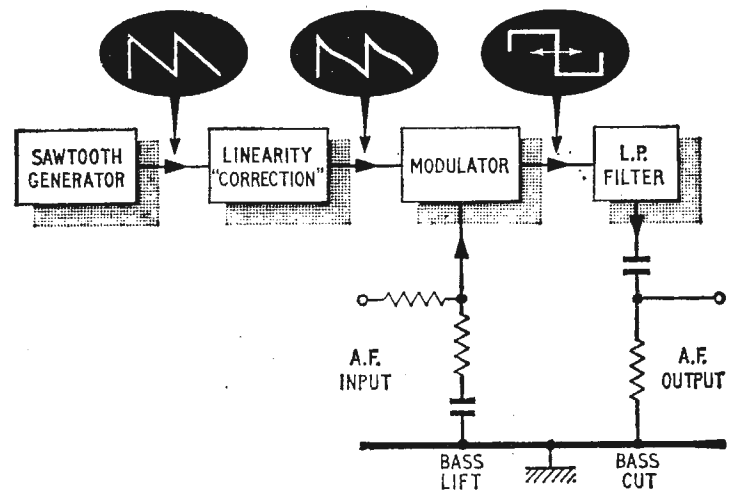

Fig. 14. Frequency-dependent linearity correction.

amplifier can be expected to remain "up to spec." for a long time. This is in contrast with many present-day valve amplifiers which will only provide their specified performance with new valves, and give a gradually deteriorating performance as these age, particularly if the ageing process is not equal in the output valves. The p.d.m. system is essentially a "go" or "no go" system.

Secondly, new devices, viz., thyristors (silicon controlled rectifiers) can be contemplated for audio amplification, whereas these devices cannot be used in the traditional form of circuit.

The advantage common to existing transistor circuits that the impedances are such that an output transformer need not be used is retained.

As always, a new technique opens up possibilities which may not be apparent with previous circuit arrangements. For example, a new method of providing motional feedback.

There are, of course, disadvantages. In many cases low-pass filters are needed, and some thought is necessary as to the best configuration. This is because filters normally operate between specified source and termination resistances, whereas in this case the source resistance is virtually zero, and the requirements are rather different. Careful screening may be necessary to prevent radiation troubles. It must be admitted that the circuits appear a little more complex at this stage, but it must be realized that this may well be because we are not so familiar with them. There is yet plenty of time for the usual clever dodges and commercial compromises to be evolved. For example, the use of the centre portion of a sine wave rather than a sawtooth as the primary waveform, or the combination of modulator and output functions in a single stage.

A further possible disadvantage is that high frequency transistors are called for, if the whole of the audio band is to be covered with low beat note distortion. However, the system offers a low dissipation figure for the output transistors, which is a considerable advantage.

It is hoped that the contents of this article will have whetted the appetite of some for a little experimental work in this field. In this case its purpose will have been satisfied.

REFERENCES

1. H. S. Black, "Modulation Theory." (Book published by D. Van Nostrand Co.)
2. B. D. Bedford, Patent 389,855, 25/9/31.

OSCILLATORS: a Monistic Approach

2. — TWO-TERMINAL CIRCUITS

By THOMAS RODDAM

THE previous article, after mentioning the class of oscillators which can be related to a two-terminal network system, discussed the great variety of oscillators which can be analysed as the tandem connection of an amplifier and a passive four-terminal network. We must now consider the oscillators which are based on a two-terminal connection. Any system of classification leads to trouble, because a revision in the layout of the circuit diagram can make a circuit appear to fall into one class rather than the other. This can actually justify the use of rigid classification, as we shall see in a discussion of the Clapp circuit, because it can force us into taking

define, in one way or another, the short- and open-circuit stability of the system. I do not wish to repeat the discussion of this question again. I do, however, want to make use of some of the ideas which formed the basis of a study of negative resistance circuits used in transistor inverters.

A convenient starting point is what may be called the conventional theory of the linear negative resistance oscillator. In this we have the simple condition that the negative resistance is numerically equal to the circuit loss resistance and that the configuration is one which can oscillate. Although that may look as though it is begging the question the studious reader can track down serious papers which adopt just this line and which ignore the difference between short- and open-circuit stability. It is perhaps more straightforward to allow a small amount of non-linearity to appear and to draw a linear negative resistance load line across the nearly linear negative resistance characteristic. Two versions of this are shown as Figs. 2(a) and 2(b). We are concerned with the central intersection at U. In Fig. 2(a) the resistance corresponding to the load line is rather higher than the negative resistance, a slovenly way of saying something which would take too many words to keep repeating. The circuit is, say 1,000 ohms load with -900 ohms negative resistance. If the negative resistance device is of the short-circuit stable type this intersection point is unstable. The circuit will oscillate and since the presence of a short-circuit will make it stable it can only oscillate if the tuned circuit looks like an open circuit once the loss resistance is excluded.

Certainly there are instability conditions with a series resonant circuit, but they introduce either zero or infinite frequency. We can exclude these normally, because as we have seen in our earlier discussion of negative resistance circuits, the impedance is only in the negative resistance half of the impedance plane over a limited frequency range. The only condition of any interest is therefore with a circuit of the type shown in Fig. 2(b).

When we turn to Fig. 2(b) we have a load-line resistance which is less than the negative resistance,

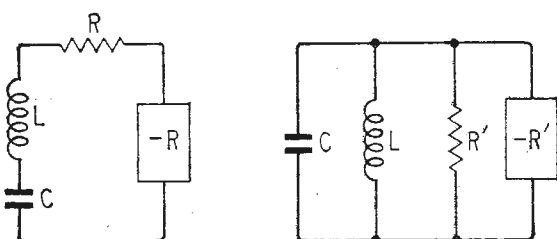

Fig. 1. Basic two-terminal oscillator.

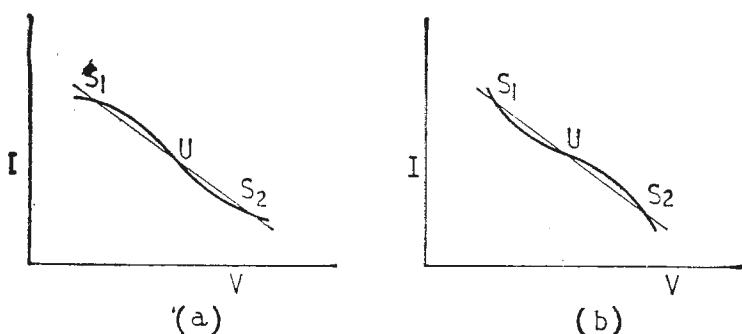

Fig. 2. Linear load lines in relation to negative resistance characteristics with two types of non-linearity.

account of elements which are implicit in our analysis but are concealed by absorption in other elements in the practical circuit.

The usual way of describing a two-terminal oscillator is to make use of the circuits shown in Fig. 1. In the first of these we connect an ordinary series resonant circuit with resistance R , the loss resistance, to the terminals of a negative resistance box which looks like $-R$ and we say that the net resistance in the loop is zero, so that a current at the resonant frequency will be completely undamped. In the second circuit we have a parallel, anti-resonant circuit and we show the loss resistance as a parallel resistance R which is again neutralized by the parallel negative resistance $-R$.

The reader who has been doing his homework regularly will be familiar with the situation revealed by these two diagrams. They conceal the fact that it is not sufficient to say that the impedance between two terminals is, say, $-1,000$ ohms. We must also

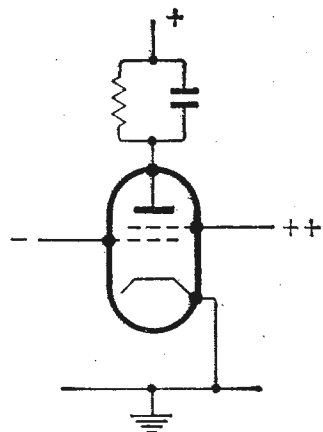

Fig. 3. Basic dynatron oscillator.

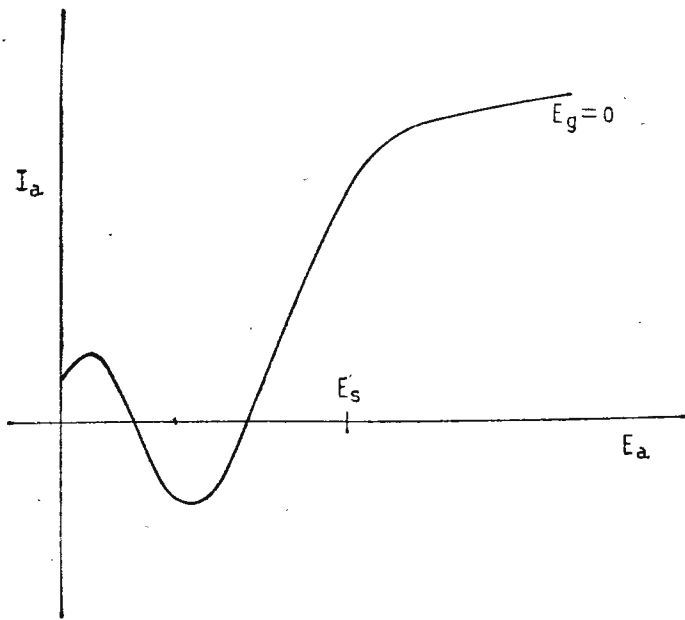

Fig. 4. Dynatron negative resistance characteristic.

a condition which will allow the circuit to oscillate if there is an open-circuit stable type of negative resistance and if there is some frequency at which the reactive elements do not impede the operation. This kind of reasoning leads us immediately to the configuration of Fig. 1.

The average slope of the negative resistance region, whatever we may mean by average in this context, between S_1 and S_2 in both diagrams of Fig. 2 is equal to the slope of the load line. We may, rather naively, suggest that the circuit will oscillate between S_1 and S_2 . I should not like to put any money on this because the amplitude depends on the balance between energy pumped in when the slopes of the two lines differ in one sense and that absorbed when they differ in the opposite sense and I am not sure that the result of a comparison of the two integrals will give such a simple answer. In any event, we cannot use such a delicate balance of non-linearity.

This is not a difficulty which is peculiar to the linear two-terminal oscillator, for we have exactly the same kind of problem with the four-terminal oscillator. Similar methods are used to control the amplitude of oscillation by varying the "factor" of the active system.

The early literature of this type of oscillator seems to indicate that engineers were in flight from the cult of the personality and were seeking refuge in the purer world which is inhabited by the classical scholar. The dynatron is one of the old favourites, although I doubt whether it is much used nowadays. The basic circuit is shown in Fig. 3 and for its operation it depends on secondary emission from the anode of a screened-grid valve. This rather old-fashioned term is used because the modern tetrode will in general not show the negative resistance region indicated in the characteristic of Fig. 4. Indeed I was about to say that they don't make valves like this nowadays, the favourite cry of the old hand, but I see that the 6164 (at $E_g = -50V$) and the 5763 (at $E_g = -10V$) show, in the Brimar curves a small negative resistance region. There is just a little of the old Adam left in these characteristics, but I should not like to rely very much on it, because if they can design it out of the valves they will.

The transitron, shown in Fig. 5, is a rather safer bet and is, of course, the parent form for a

whole set of non-sinusoidal wave-form generators. As far as language is concerned, however, my favourite is the kallirotron, which is the name given to a circuit based on the ordinary two-valve multivibrator. This is, of course, only one of the systems which are still of great interest and we might perhaps record, before going on to this matter, the proliferation of negative resistance oscillator circuits which we saw in the distant days of the point-contact transistor. Device negative resistance is probably never really satisfactory for anything but the simplest circuits.

It is tempting to say that the active circuit design for a two-terminal oscillator is more significant, more important, than the amplifier design for a four-terminal oscillator system. I think this is an illusion which is produced by our experience. Simple amplifier design is a rather bread-and-butter activity which our chief interest is in refinements of the circuit or the use of new devices which are not so very different from the old devices. Negative resistance circuits, on the other hand, are very much less familiar to most designers and they are more easily satisfied by the sheer fact that they have got a negative resistance and by the circuit techniques needed to get it.

This attitude will probably change now that we are beginning to use the negative impedance converter as a network element. I wrote something about this side of the story fairly recently and I can therefore skim fairly lightly over the circuit details. The story really begins with the use of negative resistance for amplification in telephone lines and with the study of the circuit shown in Fig. 6. This is a greatly simplified composite of the two basic circuits: we connect one of the two resistances and look in at the other end. When R_2 is connected we see at the anodes of the valves a resistance of approximately $-R_2$. When R_1 is connected we see at the cathodes of the valves a resistance of approximately $-R_1$. As we have already discovered in our earlier studies of this circuit, the negative resistance seen at the anodes is short-circuit stable, while the negative resistance at the cathodes is open-circuit stable.

The kallirotron circuit, when we look at it again,

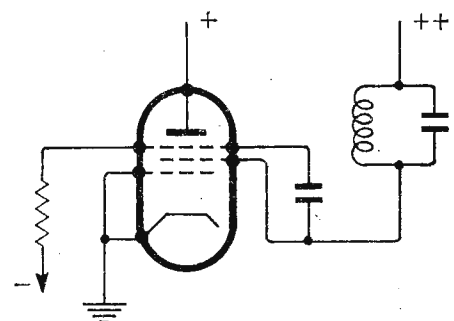

Left:— Fig. 5. The transitron oscillator.

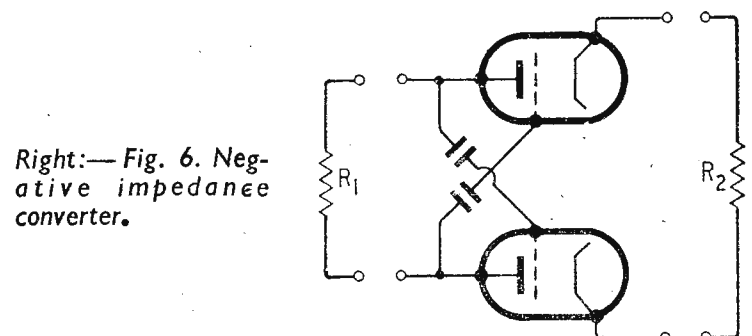

Right:— Fig. 6. Negative impedance converter.

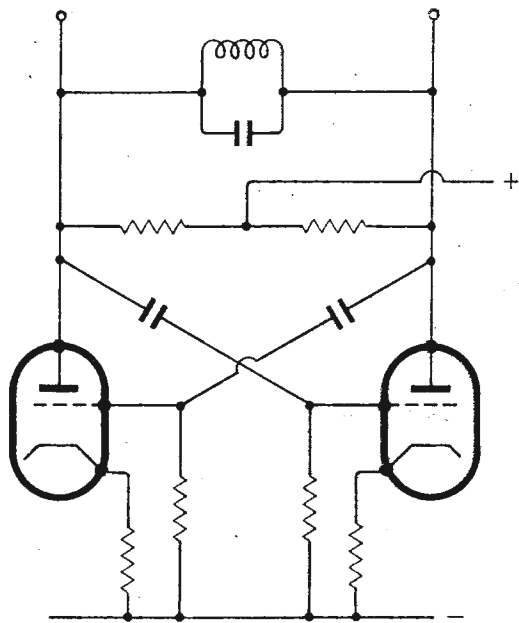

Fig. 7. Oscillator using the network of Fig. 6.

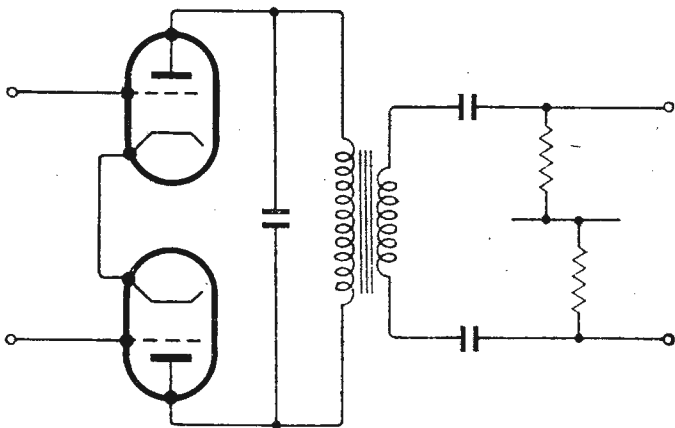

Fig. 8. Four-terminal equivalent of Fig. 7.

is just the oscillator circuit we shall get by connecting an anti-resonant circuit from anode to anode, and can be drawn in the usual form in Fig. 7. As soon as we start to draw the circuit in this form we start to play about with it. We put in the cathode resistance values which suit the d.c. conditions for the valves and, in consequence, we have a negative resistance value very much lower than our loss resistance. Sometimes we find that the designer allows the valves to drive up into the low-gain regions, sometimes the oscillations are controlled by using rather low values of anode feed resistance. Then we get the designer who prefers to treat the circuit as though it were a four-terminal circuit and who adopts the form shown in Fig. 8. He may use a transformer and omit the capacitors or he may use an autotransformer. This way of handling the circuit leads to the right answer and has only two disadvantages. The first disadvantage is that it interferes with the classification scheme which we are exploring. You may feel that there is a suggestion here of the attitude of the French pensions official who wrote to a claimant who had been travelling abroad that his medical certificate showed that he was alive now, but a certificate was also needed to show that he was alive in the previous quarter. The second disadvantage is that we shall want to discuss large-amplitude non-linear oscillations, and the negative resistance approach is then much more convenient.

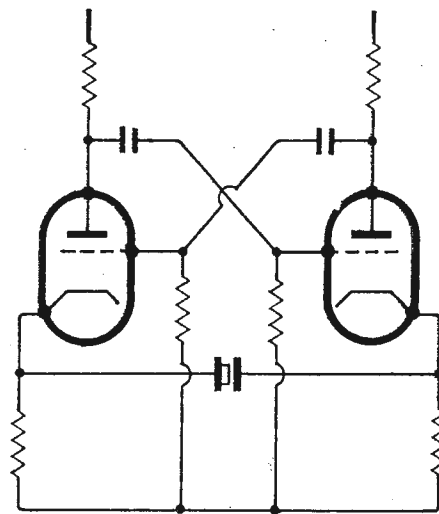

Fig. 9. Crystal-controlled multivibrator oscillator.

The inclusion of the transformer effect in the negative resistance is quite simple, as we shall see.

The other important application of this type of circuit is in the crystal oscillator circuit shown in Fig. 9. This circuit operates, of course, by providing a near short-circuit between the cathodes of the valves at the resonant frequency of the crystal. Provided that the loss resistance of the crystal is less than the net value of negative resistance the circuit will oscillate.

Most constant-frequency oscillators operate with signals of small amplitude in the linear region of the characteristic and the use of push-pull circuits is thoroughly uneconomic. We can regard the valves or transistors as being connected in parallel and we know that for amplification purposes the tandem connection is the one to use. There is a hint, too, that we shall often find it convenient to use a transformer because the impedance of a tuned circuit may not be in the region most convenient for the active circuits we shall use. We may look at the circuit shown in Fig. 10, a circuit which was used in a discussion of transistor inverters. There it was shown that if a high impedance was connected at C we should have a negative resistance facing R_1 , and that this would be a short-circuit stable type of negative resistance. If R_1 is connected and if the parameters are properly chosen we can look in at C and find a short-circuit stable negative resistance there. This circuit will act as a sine-wave oscillator if an anti-resonant circuit is connected across C and if the conditions are such that we remain in the linear region.

A variation of this is the circuit shown in Fig. 11. A good many years ago I analysed this circuit from several different points of view. One way which I did not use was to show, as can be done quite easily, that the impedance looking in is a short-circuit stable negative resistance which is approximately $-n^2R$, by combining the ideal transformer with the inductor of the anti-resonant circuit a very good and simple oscillator is obtained. Like all the circuits discussed so far it operates at the characteristic frequency of the tuned circuit.

We can construct this circuit by using a different form of ideal. The network of capacitances shown in Fig. 12 is an ideal transformer of ratio 1:n provided that C is allowed to approach infinity. Since we are considering general principles we can accept this as a possible situation to which our real

situation will be an approximation and we can go on to draw a practical oscillator circuit in Fig. 13. Once we accept the resistance as being a component which must be associated with the valve we see that this is another way of arriving at the Colpitts circuit. The design method for this circuit, however, concentrates attention on the loss resistance of the tuned circuit. Very little attention is needed to the usual problem of the Hartley and Colpitts circuits, the variations in source impedance, because if we draw the network in the four-terminal arrangement we see that the negative current feedback in the valve is looking after the impedances by making them very high.

I want to digress at this point from the main stream of oscillator classification to look even more closely at this circuit. Something which looks very like it was discussed by G. G. Gouriet (*Wireless Engineer*, April 1950) with a conclusion which at first sight is pretty confusing. We have seen that the logic of development from Fig. 11 to Fig. 13 gives us a negative resistance which is short-circuit stable. We know that this is quite right, because if we put an anti-resonant circuit across the input terminals of Fig. 11 we get an oscillator. Gouriet's

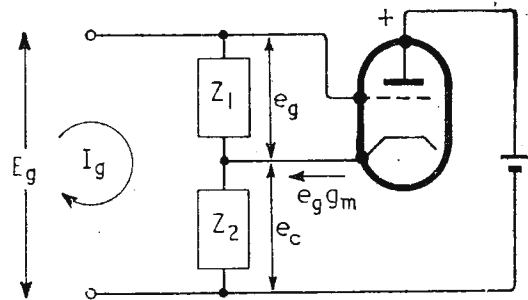

Fig. 14. Generalized form of the circuit of Fig. 13.

Fig. 4(b) is shown as Fig. 14. For this circuit we can take his equations (Appendix 1 *loc. cit.*)

$$e_c = Z_2(I_g + e_g g_m)$$

$$e_g = Z_1 I_g$$

and

$$E_g = e_c + e_g$$

$$= I_g(Z_2 + Z_1 + g_m Z_1 Z_2)$$

If $Z_1 = 1/j\omega C_1$ and $Z_2 = 1/j\omega C_2$,

$$\frac{E_g}{I_g} = Z_{in} = \frac{1}{j\omega} \cdot \frac{C_1 + C_2}{C_1 C_2} - \frac{g_m}{\omega^2 C_1 C_2}$$

Now in the Clapp circuit we get this system to oscillate with a short circuit, a series circuit, a resonant circuit, connected to its terminals and we draw the conclusion that the term $-g_m/\omega^2 C_1 C_2$ is open-circuit stable. If we see how it changes as g_m gets smaller, the ends of the negative resistance region, we get the negative resistance going to zero and we can then add in the effect of grid current and develop an S-shaped characteristic. We must be able to reconcile these two conflicting views and the key to the reconciliation lies in the choice between a parallel and a series RC network. Transformation from one to the other is straightforward and tedious, just the problem needed to pad out an examination paper. If you feel disposed to examine this for yourself I would say that the answer seems to be obtained most easily by working in terms of admittances, and that the resulting negative resistance is

$$-(g_m/\omega^2 C_1 C_2 + 1/g_m)$$

When $C_1 C_2 \rightarrow \infty$ this reduces to $-1/g_m$, which, quite clearly, gives us an infinite value as $g_m \rightarrow 0$ and thus gives us the N-shape we associate with a short-circuit stable negative resistance. From this it is clear that the resonant circuit must be presenting an inductive impedance to the terminals in order to take up the capacitance effect of the active network. I feel that there is an Awful Warning here. We have seen in previous discussions of these negative resistance networks that the whole behaviour of the system impedance as the frequency varies is of vital significance. Yet in discussing a circuit of the type of Fig. 14 we may try to separate out the negative resistance from the associated reactance. Whenever this happens we must look very carefully to see what we are about: this is especially true in any situation in which we are using a capacitance network as a transformer equivalent and are implicitly absorbing a negative capacitance.

The need for some classification operation is indicated to my mind by the basic circuit of Fig. 15(a). This is described in some texts as a feedback oscillator and is analysed by considering the network of Fig. 15(b). We can, however, see very easily that the impedance facing the anti-resonant circuit is such that a voltage V will cause a current

Right:—Fig. 10. If a high impedance is connected at C a short-circuit-stable negative resistance faces R_L .

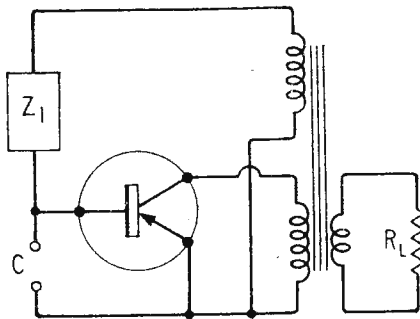

Left:—Fig. 11. A variation of the arrangement of Fig. 10.

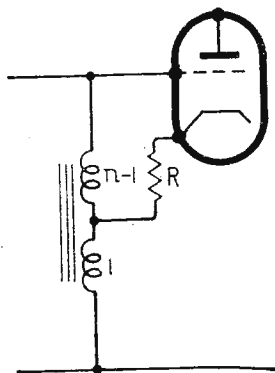

Right:—Fig. 12. If C approaches infinity this network is equivalent to an ideal transformer of ratio 1:n.

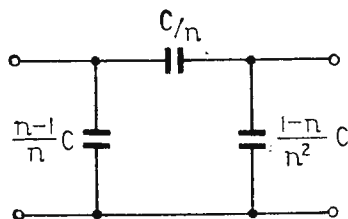

Left:—Fig. 13. The practical oscillator derived from Fig. 12 is virtually the Colpitts circuit.

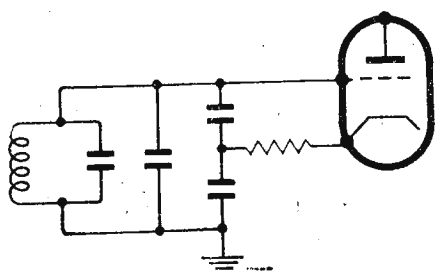

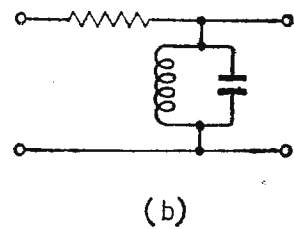
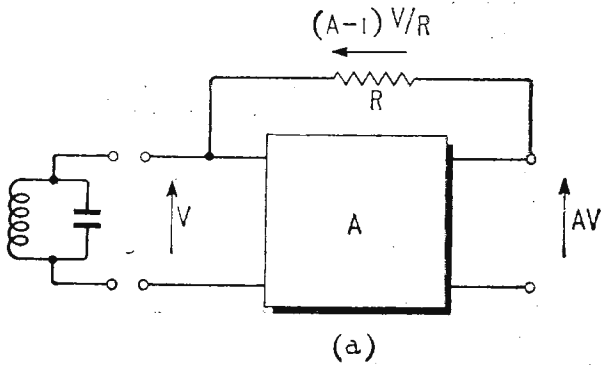

Fig. 15. Feedback or negative-impedance oscillator?

$(A-1)V/R$ to be driven back into the source, provided that we make the usual assumption that the amplifier has infinite input impedance. This gives us an input impedance, with the feedback resistance connected, of $R/(1-A)$ which, if $A > 1$, will be negative. We may very properly regard this as a negative impedance oscillator. In fact most of the negative impedance converter circuits which I discussed some little while ago can be rearranged into some form like this. We can design the amplifier according to known methods to make the gain A a pure number of high stability, though we should do this even if we adopted the feedback point of view. I think, however, that we may find the negative impedance approach more convenient in a variant of this circuit which I shall discuss later.

There is no space to discuss the large-amplitude negative resistances circuits this month and we must postpone this very important class of oscillators. I feel that we can say that a basis has been established for a split into the two main types of oscillator but that it is only too easy to allow an oscillator which belongs, when generalized, to one class to be regarded, in its special form, as belonging to the other. The Gouriet-Clapp circuit, in particular, can be generalized into the Colpitts circuit or into something which is really the circuit of Fig. 15(a) when the capacitance transformer is included. There are moments when I feel like the African clerk described by Graham Greene who filed documents on local-grown tobacco under the heading "transport."

LETTERS TO THE EDITOR

The Editor does not necessarily endorse opinions expressed by his correspondents

Failure Rates

IN your review of the Second I.E.E. Symposium on Reliability you report the supposed "necessity for assuming one failure where none was suffered, in order to get a figure." This idea did indeed seem prevalent at the Symposium, but put in that form it is not well founded.

The crude approach is to say that, since nothing is known of behaviour beyond the test period, it is safest to assume that a failure would have happened immediately afterwards. If this hypothetical failure occurred *immediately* afterwards, it is practically the same as if it had occurred just inside the test period.

There is, however, a quite sound statistical basis for calculation. The specification of a failure rate in per cent per 1000 hours or the like presupposes that there is a small and uniformly distributed risk of failure, say α per hour where α is of order 10^{-5} or less, and this is the condition for the validity of the Poisson law ("the law of rare events"). Under this law, the probability that just r failures occur in time t (where r may = 0, 1, 2, etc.) is

$$P(r) = (\alpha t)^r e^{-\alpha t} / r! \dots \dots \dots (1)$$

Since $(\alpha t)^0 = 1$ and $0! = 1$, the probability of no failures is quite properly given by

$$P(0) = e^{-\alpha t} \approx 1 - \alpha t \dots \dots \dots (2)$$

and the risk of some failures (one or more) is $P(f) = 1 - P(0) = 1 - e^{-\alpha t} \approx \alpha t$.

The problem now is to decide how much importance to attach to the results of one or a few tests. If only one test was run, and the ultimate application is fairly critical, it may be thought reasonable to suppose that

the test was a lucky one, with odds of nine to one against an equally good result occurring generally; and one therefore equates $P(0)$ to 1/10th, whereupon (αt) has probability 0.9 which is not far out from saying that one failure would have occurred in that time. But if the test is run on a batch of 100 specimens, and none fail, the value of αt appropriate to this new condition will be very nearly 100 times smaller. Thus on the assumption of the Poisson law, running a test on a number of specimens simultaneously is very nearly equivalent to running a test on a single specimen for the cumulative time.

Of course one may not be content with only 9:1 odds against the run succeeding by chance, but given the basic formulae it is not difficult to adjust the calculations. The important point is that for very small numbers statistical calculation is almost meaningless and can only be applied through large safety factors, but the number which is critical is the number of items under test, not the number of failures; so zero failures out of a large number is perfectly amenable to statistical interpretation.

Sonning Common, Reading. D. A. BELL,
AMF British Research Laboratory.

"Transistor RC Oscillators and Selective Amplifiers"

IN his interesting and useful article in the December 1962 issue Mr. Butler discusses circuits which make use of null networks or 180° phase-shift networks.

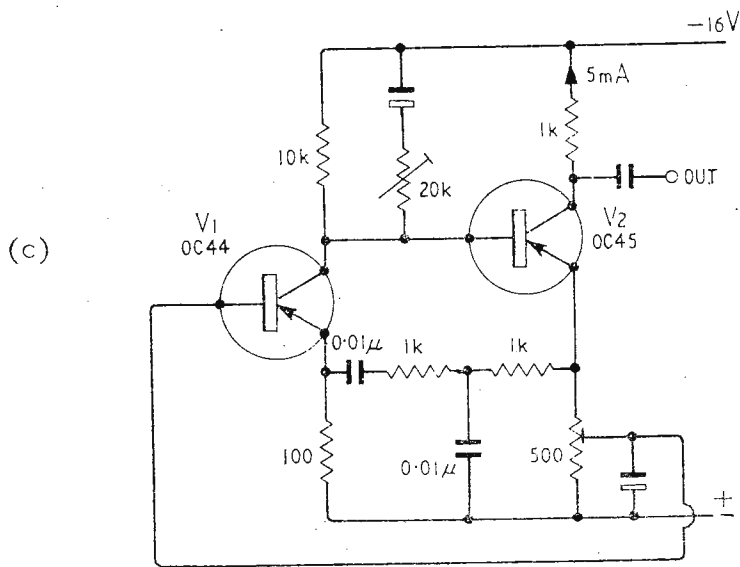
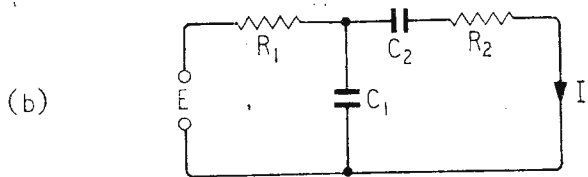
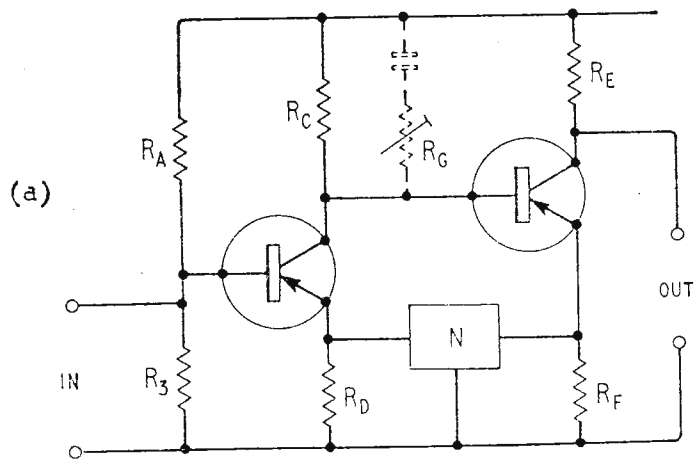

Another method of effecting a regenerative tuned amplifier is indicated in the accompanying Fig. A, where N is a positive feedback network having zero phase shift at one frequency. This arrangement is attractive because it leaves the base of the first transistor free to accept an input signal, and the collector of the second transistor free for taking an output. The network must be able to work when connected between low impedances since V2 is an emitter-follower as far as N is concerned, while V1 is a common-base amplifier. A suitable network is shown in Fig. B. It is derived from a current-driven "Wien" network, and its vital statistics are as follows:

$$f_0 = 1/2\pi(R_1R_2C_1C_2)^{1/2}$$

At f_0

$$\frac{E}{I} = R_1 + R_2 + R_1(C_1/C_2) = R_T \text{ (say).}$$

If $R_1 = R_2 = R$, and $C_1 = C_2 = C$ then $f_0 = 1/2\pi RC$ and R_T becomes $2R$.

The condition for oscillation is that the collector load resistance of the first transistor should be rather greater than R_T .

Some practical points should be noted. First, since R_T depends on R_1 and R_2 in the way shown in the formula above, variable resistance tuning is impracticable in a wide-range oscillator; the loop gain would need continuous adjustment. Variable-capacitance tuning is better; it is then only necessary to keep the ratio of the two capacitances constant to keep R_T constant. However, range-changing is still a problem, since R_T would be different on each frequency band. In short, the circuit is really only suitable for fixed-frequency

working at low frequencies, or one-band operation at high frequencies, using capacitance tuning.

Regeneration control or amplitude stabilization can be effected by adjusting R_C . In a direct-coupled circuit this is best done by means of an extra resistor R_G with a blocking capacitor. (In an oscillator, R_G may be a thermistor: S.T.C. type "R" thermistors have a temperature rise of $50^\circ\text{C}/\text{mW}$, so the power required to operate them can easily be obtained. I have not tried one in this circuit but type R24, with a cold resistance of $20\text{k}\Omega$, looks a good bet.)

The tuned frequency will be found in practice to be lower than the calculated value. In the oscillator circuit of Fig. C, for example, the calculated frequency was 16 kc/s and the actual frequency about 13 kc/s. The discrepancy arises from two causes. First, the internal impedances of the transistors, looking into the emitters, add to the tuning resistances. Secondly, the input impedance of V2 is not a pure resistance: it is capacitive, because the emitter load of V2 is capacitive. This introduces a phase shift into the feedback loop. However, the frequency is quite stable and the oscillator generates good sine waves.

An alternative tuning network in which inductors are substituted for the capacitors is possible, but has the disadvantage (in this circuit) that it does not block d.c. The oscillator may also be used with a series-tuned LC circuit connected between emitters, instead of an RC network.

Croydon.

G. W. SHORT

F. BUTLER in his article in the December 1962 issue does not describe the simplest selective amplifier of the types considered, which is surely the two-valve circuit obtained by "pruning" redundant components from his Fig. 16 (p. 588). This gives the circuit of the accompanying diagram. V1 is best made a silicon type for which V_{be} will be about 500mV. Thus the emitter potential of V2 (and hence its emitter current) becomes well defined at $500\text{mV} + (R_3 + R_5) I_{b1}$. With the parallel-T network tuned to a null at f_0 , the selectivity of the current gain of this circuit will be as follows:

Current gain at high frequencies	0dB (unity)
" " " $3f_0$	+10dB
" " " $2f_0$	+14dB
" " " f_0	>30dB
" " " low frequencies	$(R_3 + R_5)/R_6$

The gain at f_0 is set by the forward gain of the transistor pair and at other frequencies by negative feedback only. The response at low frequencies can be improved by suitable choice of C_1 and R_1 . Positive feedback can be introduced into this basic circuit by, for example, a resistor between the base of V1 and the collector of V2,

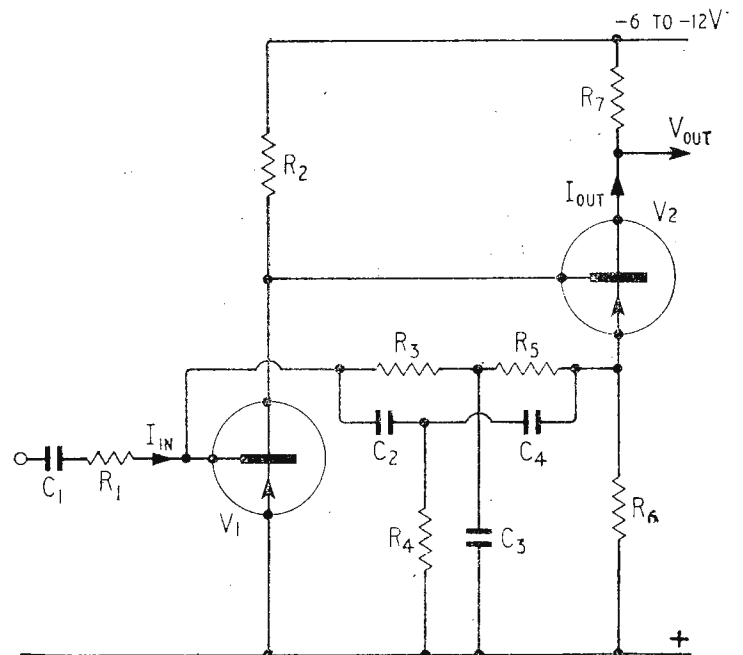

to increase the gain and selectivity at f_0 , but only by degrading the inherent high stability of the circuit.

The circuit may similarly be made the basis of a highly stable oscillator.

Edinburgh 8.

M. R. NICHOLLS.

The author replies:—

In terms of sheer circuit simplicity I believe that my Fig. 11 is even more economical in components than Mr. Nicholls' circuit which, as he says, can be derived from my Fig. 16 by leaving out what he describes as redundant components.

For use at a single frequency his circuit has some excellent features. It is d.c. coupled, provides stabilized base bias and uses no large electrolytic capacitors. Against this, two of the resistance elements in the twin-T network also act as biasing resistances for the first transistor. Tuning by resistance variation would alter this working bias and cause undesirable changes in the operating points of both transistors. This is my major objection to the circuit. A minor one is that the output is at a relatively high impedance.

In my Fig. 16, base bias for the transistors is derived from a network which is independent of the twin-T circuit. Tuning by resistance variation does not affect the standing bias. Two more components provide variable regeneration, a feature which is absent from Mr. Nicholls' circuit. Finally, the second transistor in Fig. 16 is bootstrapped to give high gain. Removal of the so-called redundant components clearly affects the performance of the amplifier in quite basic ways.

Readers may be interested in another circuit which bears some resemblance to that due to Mr. Nicholls. It was described by E. I. Kuflevskii in the Soviet journal

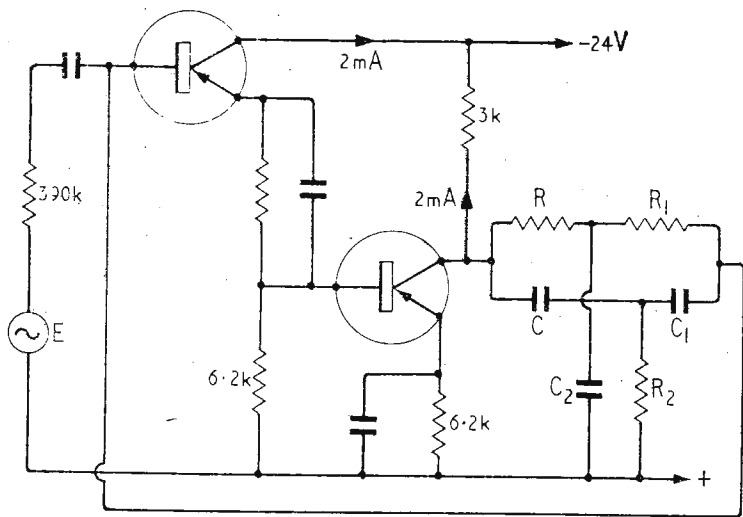

Circuit due to E. I. Kuflevskii.

Radiotekhnika, Vol. 16, No. 9, 1961 (available in translation from Pergamon Press).

As with Mr. Nicholls' circuit the arrangement is best suited for single frequency operation, since resistance tuning alters the transistor bias and, again, the output is at high impedance.

Most writers favour the symmetrical twin-T circuit but Kuflevskii recommends an unsymmetrical arrangement.

For the symmetrical case:—

$$R = R_1, C = C_1, C_2 = 2C \text{ and } R_2 = R/2.$$

In the unsymmetrical case:—

$$R_1 = kR \quad R_2 = \frac{kR}{m(1+k)}$$

$$C_1 = \frac{C}{k} \quad C_2 = \frac{C(1+k)}{mk}$$

Preferred values of the various constants are given in the article as $k = 2.75$, $m = 1.42$ and $R = 10k\Omega$.
Cheltenham, Glos.

F. BUTLER.

"LC Oscillator Design"

BECAUSE the linear theory of oscillators is so exclusively established, but of little practical use, we attempted, in our article in the November and December 1962 issues, to present oscillators from the opposite extreme point of view. We are therefore grateful to Mr. Butler (p. 28 of the January issue) for helping to show the link between these different viewpoints by stating the conditions for unity loop gain in a "cross-connected" long-tailed pair. The classic approach to oscillators is helpful if use is made of the describing function method of allowing for non-linearities by means of an amplitude dependent transfer function, ref. 1. The definition of an effective mean g_m (g_m), when the valve is operating linearly for only part of the cycle is a commonly used empirical representation of this theory, which is only of real value when the form of the non-linearity is specified. It is the characteristics of the long-tailed pair as a limiting amplifier which are then the crucial point.

Such a limiter is most satisfactory if the "tail" approximates closely to a known constant-current source. This requires a tail resistor of known value, across which a known voltage exists, changes in this voltage being kept small compared with its mean value (say less than 10%). As Mr. Butler observes, this criterion is not satisfied in the circuit he describes because the mean potential across the $10k\Omega$ and 500Ω resistors is determined by the grid-bias cathode current relationship, a poorly defined parameter (Ref. 2).

However, the describing function theory, like any other, is of real value only if the results it gives are worth the effort involved. For this reason the approach adopted was that of idealizing the limited sine-wave of current into a square wave, which simplifies the theory, making it of more practical use.

We were perhaps a little severe with the conventional oscillator which in many instances is not required to be a device with a precise performance. The chief applications in which we have used long-tailed oscillators have been in fields usually referred to as "electronics" rather than "radio". The technique we described then permits the sine wave to take its place along with other wave forms as a quantity which can be easily and accurately manipulated (Refs. 3 and 4).

In conclusion we would like to thank Mr. Butler for pointing out a second-order effect due to collector capacitance changes, although we have not found any difficulty due to this effect. This may be because low L/C ratios give tuning capacitors with values swamping the effect, and in addition capacitance changes are less when the transistors are not driven to bottoming. In fairness, we have not used these oscillators at frequencies above about 3Mc/s, when the effect may become noticeable.

It is, of course, such second-order effects which limit the useful range of "first-order" designs and the ultimate performance of a circuit. Nevertheless, first-order design methods and the designable class of circuit are most valuable tools for the engineer which, perhaps because of the emphasis laid on analysis, as opposed to synthesis, in training, are surprisingly little known or accepted.

M. F. SIZMUR
R. C. FOSS.

References

1. E. A. Freeman, "Phase Shift Oscillator," *Electronic Technology*, July 1960.
2. T. K. Hemingway, "Bootstrap Follower Characteristics," *Wireless World*, July 1962.
3. D. A. Humpage, "A Phase Modulator Employing Pulse Techniques," *Electronic Engineering*, January 1962.
4. R. C. Foss, "Frequency Modulated Oscillators" *Industrial Electronics*, January 1963.

A CIRCUIT similar to that described by R. C. Foss and M. F. Sizmur (December issue, p.596, Fig. 3) was recently developed for amplitude modulation of a variable

(Continued on page 91)

REVOLUTIONARY NAVAL RADIO TRANSMITTING SYSTEMS

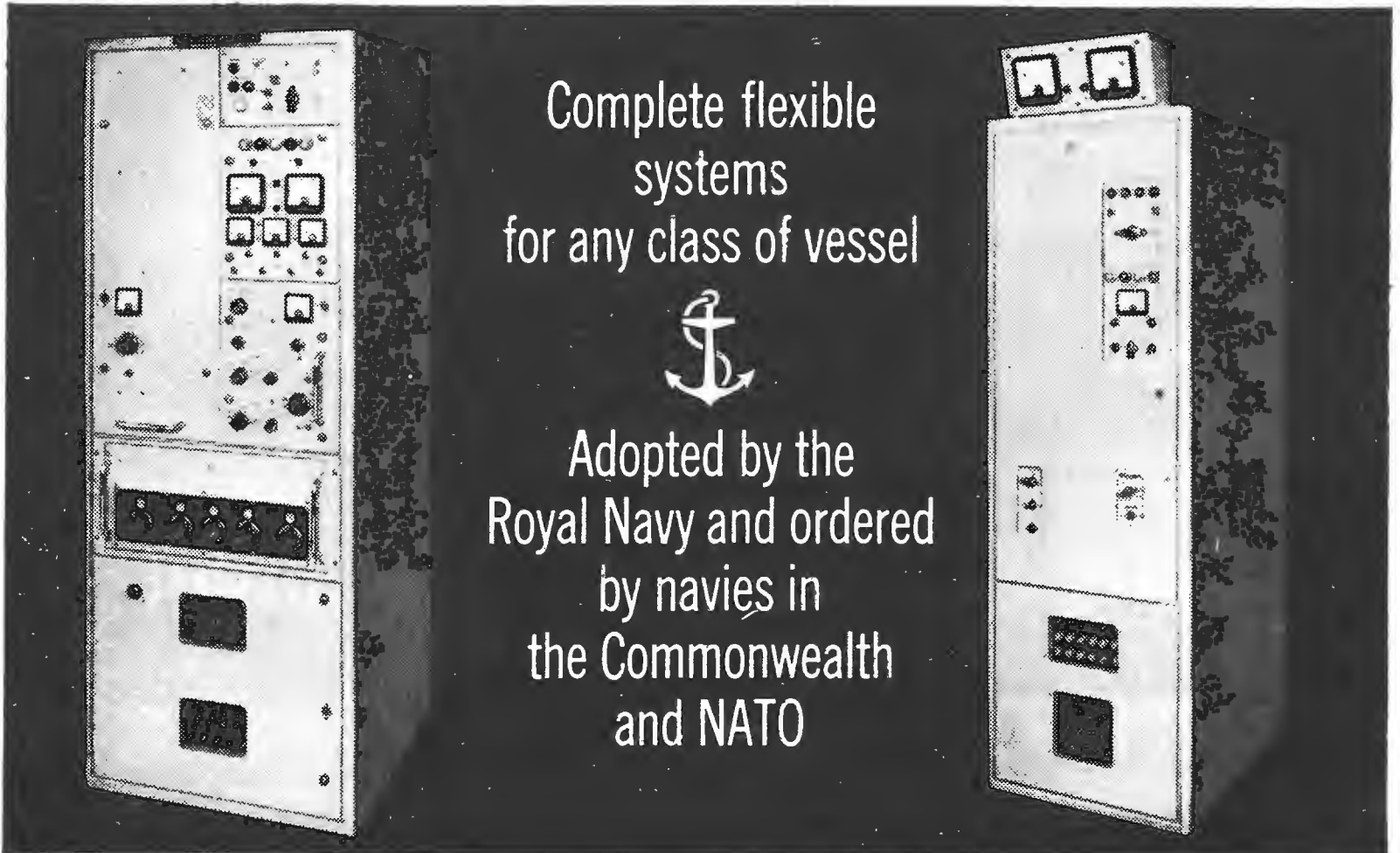

Complete flexible
systems
for any class of vessel



Adopted by the
Royal Navy and ordered
by navies in
the Commonwealth
and NATO

- Precise frequency setting and positive stability allows full advantage to be taken of SSB which provides the most reliable communications under difficult conditions of propagation or interference
- Continuous frequency coverage from 240 Kc/s to 24 Mc/s
- Covers all types of signalling
- Broadband amplifier and synthesizer system provides simplest operation and almost eliminates tuning
- Aerials can be sited for maximum radiating efficiency.

MARCONI NT 203/204 SYSTEMS



COMPLETE NAVAL RADIO AND RADAR SYSTEMS

MARCONI'S WIRELESS TELEGRAPH COMPANY LIMITED · CHELMSFORD · ESSEX

M2B



is one speech channel enough?

If your H.F. radiotelephone circuits are pushed to the limit or if you find new planning difficult—you need Rediplex for maximum utilisation and lower operating costs. Now for the first time, at low capital cost, Redifon introduce a compact ISB multi-channel system for short and medium distance communication. Four speech channels simultaneously using one carrier. The cost of the transmitting and receiving terminals, including the channelling, is far less than you would pay for regular channelling and displacement equipment—a quickly installed packaged deal. It will pay you to find out more about Rediplex. Write now for full specifications.

The Rediplex system gives you

Four simultaneous speech channels, or any combination of speech, teleprinter, facsimile or tone intelligence signals.

Four crystal controlled spot frequencies, 2 to 16 Mc/s.

100 watts p.e.p output, continuous rating (or 750 watts with the G.A.406 amplifier).

Compatible with Standard International ISB systems.

Completely transistorised receiving terminal and transmitter drive unit.

Modular construction and printed circuits.

Alternative power supply units for a.c. mains or 24 volts battery supplies.

Redifon

REDIFON LIMITED Communications Sales Division
Broomhill Rd., London, S.W.18. Tel: VANdyke 7281
A Manufacturing Company in the Rediffusion Group.

☐ Rx2

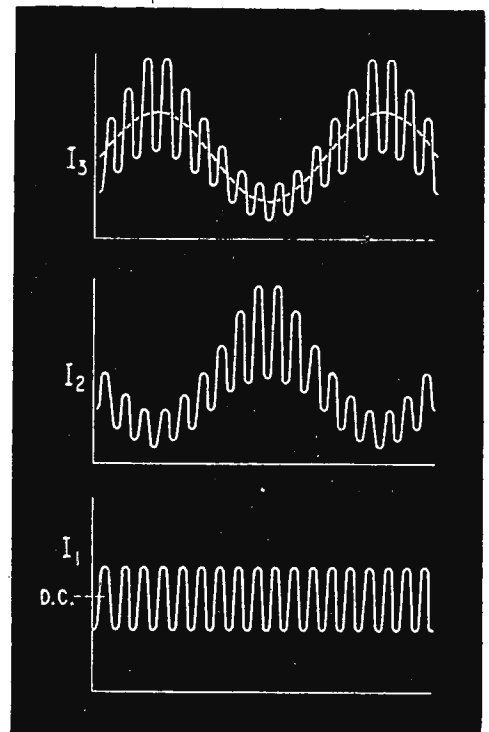
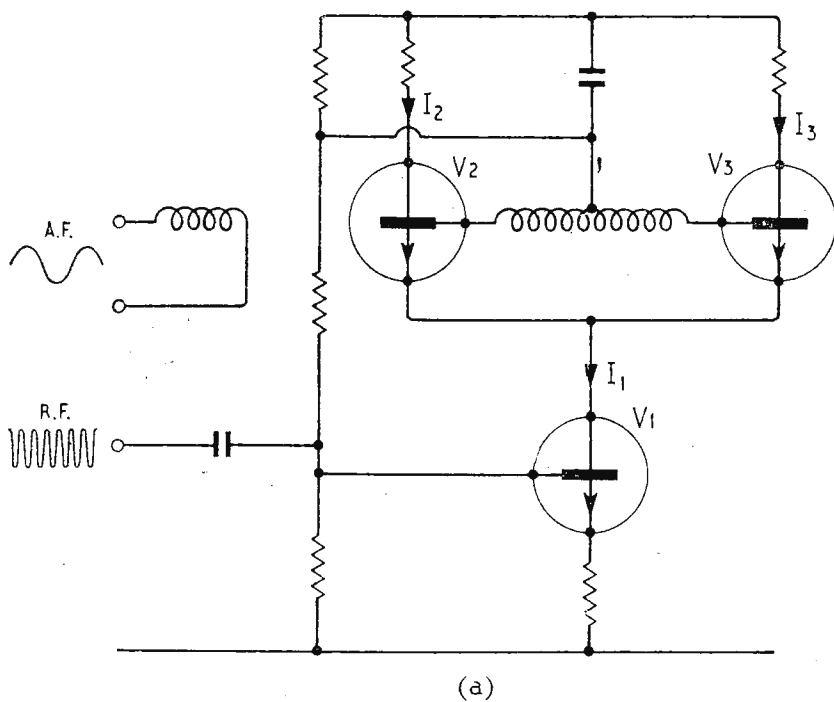

Amplitude modulation of a variable-frequency oscillator.

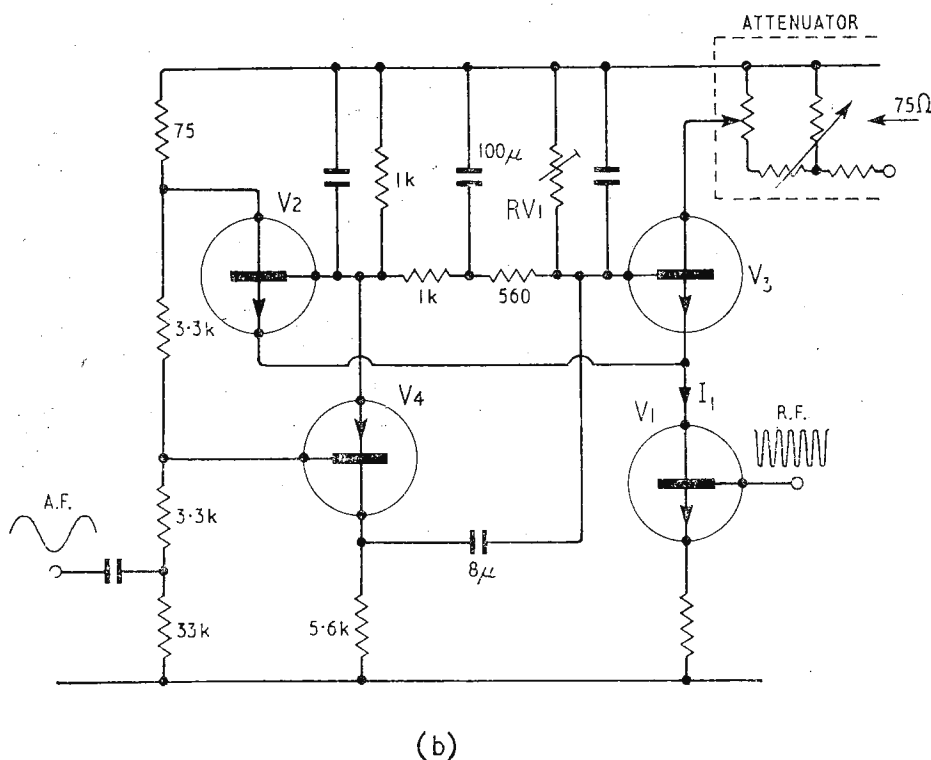

frequency oscillator. The main point of difference is that the position of the r.f. and a.f. is interchanged. Referring to the accompanying diagram (a), the d.c. and r.f. components of the collector current of V1 divide between the emitters of V2 and V3 in a ratio controlled by the difference potential of the bases. With balanced drive to the bases, as shown, the potential of the emitters of V2 and V3 remains more constant than with unbalanced drive, thereby minimizing any reaction on the input impedance of V1, hence minimizing unwanted frequency modulation of the oscillator driving the base of V1.

It will be noted that in the ideal case (and in practice for much of the usable frequency range), both the r.f. and d.c. components of the collector current of V1 divide in the same ratio in the collectors of V2 and V3, so that a replica of the modulation envelope may be recovered, without need for detection by diode or other means, from either collector. For example, the a.f. signal at the collector of V2 can be used for negative feedback to linearize the modulation while the output at the collector of V3 is fed to the attenuator.

A circuit obtaining the push-pull drive to the bases

of V2 and V3 without transformer and from a single transistor V4 is shown in diagram (b). V4 has an effective load of 500 ohms in each of emitter and collector, and operates with a moderate degree of negative feedback in the circuit shown. The current division between V2 and V3 can be adjusted by RV1 to equality or otherwise as required.

The operation of this circuit has been checked by the usual oscilloscope methods (envelope and trapezium patterns) and has proved capable of modulating carrier frequencies between 100 kc/s and 13 Mc/s with "audio" in the range 100 to 20,000 c/s. No serious distortion could be observed when modulating 100 kc/s with one-fifth that frequency, and 100% modulation was easily attained with good linearity when tested by the trapezium pattern.

The original circuit used complementary transistors (p-n-p for n-p-n) as follows:— V1 SB231, V2-V3 SB305, V4 OC139.

A more suitable choice from transistors now available would be:— V1 V2 V3 BSY26, V4 OC42.

A property of the above circuit, which may have some applications, is the opposite polarity of the modulation envelopes on the collectors of V2 and V3.

Edinburgh, 8.

M. R. NICHOLLS.

The authors reply:

In reply to Mr. Nicholls we would like to point out the distinction between his use of the "L.T.P." in which modulation is achieved by the g_m/I_e characteristics of the transistor and our use of the switched L.T.P., in which such characteristics have only second order effects.

The two circuits operate very differently—long tailed pairs are very versatile. Perhaps Mr. Nicholls would like to try one as a phase-splitter in diagram (b).

M. F. SIZMUR
R. C. FOSS

MANUFACTURERS' PRODUCTS

Circuit Protector

THE American Rowan Controller ICP is a combination of switch, pilot light, and overload protector; protection being provided by a resettable thermal contactor. The unit is suitable for use with d.c. or a.c. Auxiliary contacts (maximum rating 0.5A at 230V) can also be provided to operate an alarm circuit in the event of an overload. A trip free safety mechanism prevents the contacts from being manually held closed in a fault or overload condition. The ultimate trip point is 120% of the rated current and the trip time varies from about 16 minutes for 125% of the rated

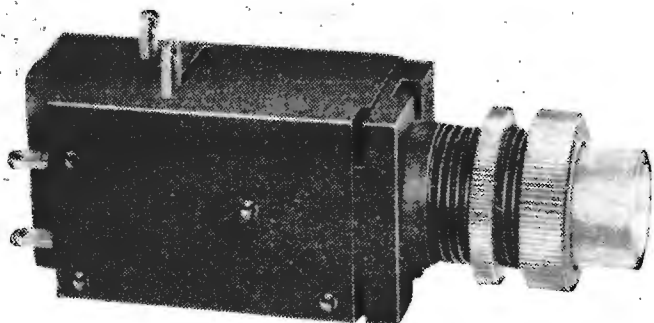

ICP circuit protector.

current through 15 to 34 seconds for 200% to 2 to 3 seconds for 600%. Full load current ratings are available with one ampere increments from four to twelve amperes; a sensitivity of half an ampere is available to special order. The maximum interrupt capacity is 300A at 50V d.c. or 250V a.c. The life expectancy is claimed to exceed 6,000 cycles at 6 cycles per minute at 100% of the rated current without any change in the trip time versus current curve. The ICP is designed for operation in the temperature range 25°C to 55°C. This unit costs about 50s; full details are available from the U.K. representative of Rowan Controller, G. S. Westbrook Ltd. of 50 High Street, Harpenden, Herts.

Triple-play Tape

A NEW type of Gevasonor magnetic recording tape has a thickness of only 17 μ , one-third that of their standard tape, and thus gives three times the playing time. It uses a "tensitized" polyester base. The new tape is available in 3, 4 and 5in diameter spools; these contain 450, 900 and 1,800ft of tape, and cost 21s 6d, 38s 6d and 65s 6d respectively. They can be obtained from Gevaert Ltd., of Great West Road, Brentford, Middlesex.

Broad-band Energy Absorbers

AVAILABLE in the form of small flat tiles (2in \times 2in) for conforming to curved surfaces the NZ series of absorbers made by the American firm of Emerson & Cuming are now available in the U.K. through Micro-cell Ltd., Electronics Division, Park Street, Camberley, Surrey. They are fabricated from ceramic dielectric and magnetic materials and have a silver backing which can be bonded with organic and inorganic adhesives. They can be used for anechoic chambers and also for transmission line terminators with temperature rating

up to 1,000°F. Reflectivity (dB down) is as follows: NZL (1in thick) >14dB to 1Gc/s and nearly 24dB at 15Gc/s. NZ2 ($\frac{1}{2}$ in thick) >10dB to 2Gc/s, >4dB to 15Gc/s. NZ3 ($\frac{1}{4}$ in thick) >15dB to 2Gc/s, 12dB at 4Gc/s and back to 20dB at 15Gc/s.

Prices are approximately £50, £30 and £40 per square foot respectively.

Four New High Power Magnetrons

PEAK power ratings for a new range of Ferranti magnetrons are 2MW for the C band (\approx 5kMc/s) model, 1MW for the X-band (\approx 10kMc/s), 400kW for the J-band (\approx 15kMc/s), and 150kW for the Q-band (\approx 35kMc/s): mean power ratings are about one thousandth of this. The cathode (high-temperature thoriated tungsten type) is heated by bombarding it by means of an electron gun. This gives a higher temperature than can be obtained by means of any normal heater having an acceptable life. Since the cathode emission is not now limited, even with the small cathodes used at higher frequencies, high powers should be obtainable at frequencies up to O-band (\approx 70kMc/s) using this bombardment technique. The bombarding gun gives a beam along the magnetic lines of force into a conical recess in the cathode. At present the bombarding heating power is stabilized by means of a saturable reactor; silicon controlled rectifiers will however eventually be used, these allowing the control unit to be made much smaller. Initial difficulties with making the (rising-sun) anode at the highest frequencies have been overcome by initially hobbing it, final dimensioning being accomplished electrolytically. Tunable versions of this range are being developed. These magnetrons are obtainable from Ferranti Ltd. of Ferry Road, Edinburgh 5.

Keithley Voltmeter

A NEW voltmeter by Keithley Instruments uses v.h.f. epitaxial and micro alloy-diffused transistors to give an amplifier bandwidth of 10c/s to 100Mc/s. The instrument has 12 ranges from 1mV to 300 volts full scale with an accuracy of \pm 2% from 20c/s to 50Mc/s and \pm 10%



Keithley Instruments voltmeter, Model 120.

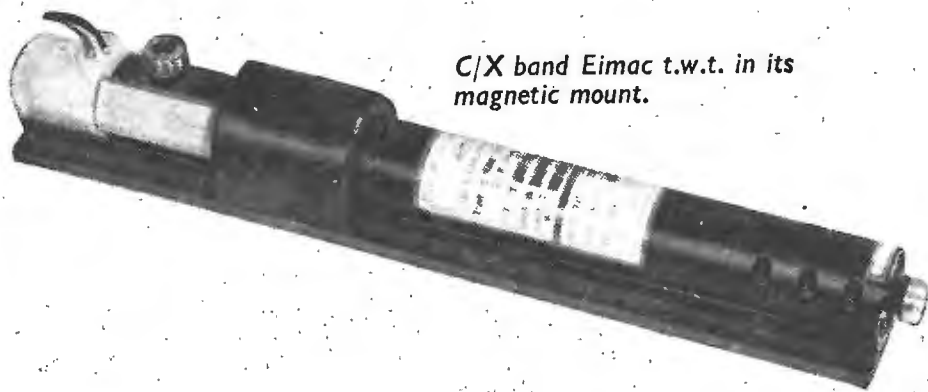

C/X band Eimac t.w.t. in its magnetic mount.

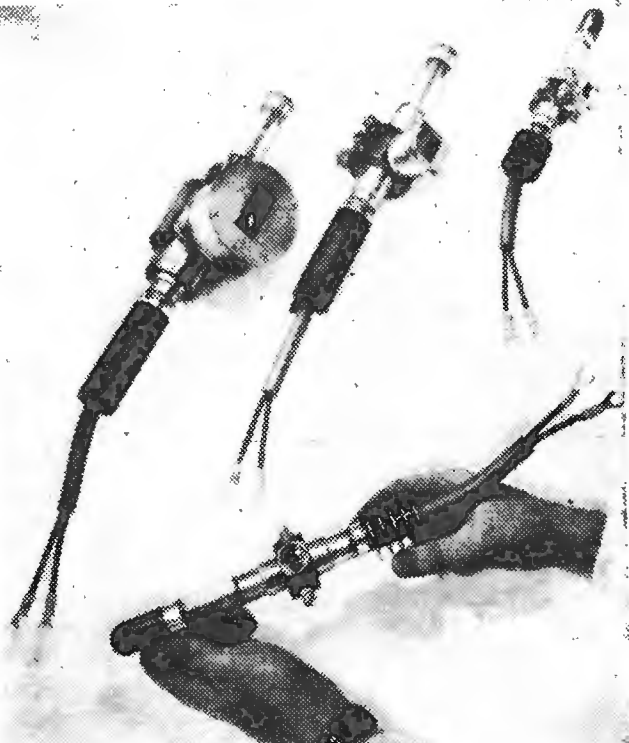

New Ferranti high power magnetrons: top, left to right are the C, X and J band models, being held is the Q band model.

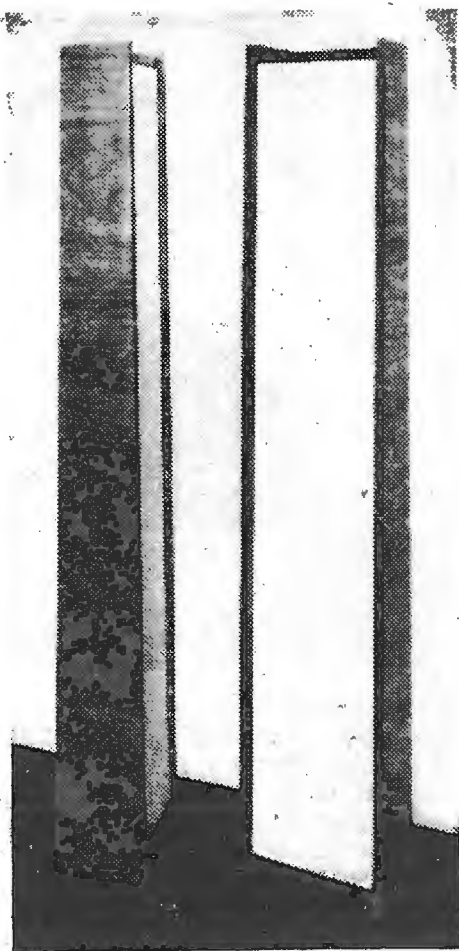

Sound Coverage column loudspeaker.

from 15c/s to 60Mc/s. At 10c/s and 100Mc/s the response is 3dB down.

The input impedance is $1M\Omega$ shunted by 20pF, but an input impedance of $10M\Omega$ shunted by 15pF may be obtained by use of an optional extra, a cathode follower probe. Used as an amplifier, the instrument provides a maximum gain of 200 and a rise time of 6 nanoseconds. The amplifier output, which is derived from a connector mounted on the rear of the case, is 200mV maximum at 50Ω on all ranges. The instrument is available in the U.K. from Livingston Laboratories Ltd., 31, Camden Road, London, N.W.1.

New Range of Travelling Wave Tubes

FEATURES of a new range of Eitel-McCullough tubes are their wide bandwidth (≈ 4.5 to 1), high-gain (30 to 60dB for small signals) and rugged construction (they can withstand a shock of 25g for 11msec or 20g vibration). Sixteen different types are available with frequencies in the range 2 to 12kMc/s and powers from 0.5 to 5W. A ceramic/metal construction is used. Full information may be obtained from Walmore Electronics Ltd. of 11-15 Betterton Street, Drury Lane, London, W.C.2.

Column Loudspeaker

ONE of the new series of loudspeakers for public address purposes which have been developed by Sound Coverage is their SCS 20/T 100 five-foot tapered column unit. This has a "line-source" characteristic and in addition a good bass response is obtained by using a tuned vented enclosure: the frequency response

is from 60c/s to 12kc/s. The loudspeaker sensitivity differences required to give a line source characteristic are provided by grading the five drive units in flux density and size: this eliminates the losses in the more usual transformer power-dividing arrangement. The drive units also have different frequency responses and this gives a better overall response. The input is from a 100-volt line and the input transformer is tapped at 20-, 15-, 10- and 5-watt loadings: the maximum possible output is more than 25 watts. Three methods of mounting are possible: by means of mounting brackets which give "on site" pan and tilt flexibility, by means of a tripod assembly, or free standing. This unit costs £32 5s and is manufactured by Sound Coverage Ltd., of 42 Hallowell Road, Northwood, Middlesex.

Transistor Tester

THE Taylor transistor tester Model 44 announced recently can be used for checking the characteristics of most modern transistors.

Among the many features of this instrument are the facility to vary the collector voltage, base current and collector current independently and the ability to test forward and reverse characteristics of point-contact diodes.

The measuring ranges cover from a minimum of $1\mu A$ to 1A I_c for p-n-p or n-p-n transistors. Parameters measured are β , I_{co} and α , the collector voltage may be varied from 1.5 to 10.5 volts in increments of 1.5 volts. As well as being able to measure its internal batteries with reference to a special scale, the instrument may be used as a voltage and current meter within the following ranges $50\mu A$, 1mA, 10mA, 100mA, 1A, 200mV and 12V d.c. at 20,000 ohms per volt. The spring-loaded termi-

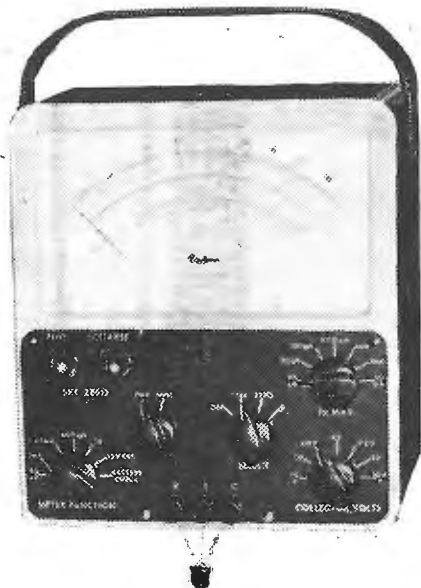

Taylor Instruments Model 44 transistor tester.

nals are of the quick release type. The indicating meter is a Taylor centre-pole meter of $50\mu\text{A}$ with a 5-in scale. A leather carrying case with shoulder strap may be obtained as an optional accessory to facilitate transport.

The price of the instrument is £19 19s 6d and a full specification may be obtained from Taylor Electrical Instruments Ltd., Montrose Avenue, Slough.

Fine Wire Splice

DESIGNED primarily for joining fine magnet wires (down to 47 s.w.g.) to lead-out wires the A-MP Fine YR splice works in principle like other crimped connectors in the A-MP range. A machine has been designed to which the U-shaped splice, mounted on polyester tape (which subsequently acts as an insulant for one side of the joint), is fed and in which stripping wheels prepare the ends of the wires to be joined. A single foot pedal effects the crimping operation, which includes wire trimming.

Particulars from Aircraft-Marine Products (Great Britain) Ltd., Amplo House, 87-89 Saffron Hill, London, E.C.1.

Cooler for Transistors

THE new Casco transistor cooler provides maximum heat transfer from the transistor both because it firmly grips the transistor can and because a notched cooling-fin design ensures turbulent air flow (around the apices of the notches). An additional feature of this device is an auxiliary plate for clamping the bottom flange of the transistor can to the cooler. As well as increasing heat transfer this provides firm fixing at centres on a

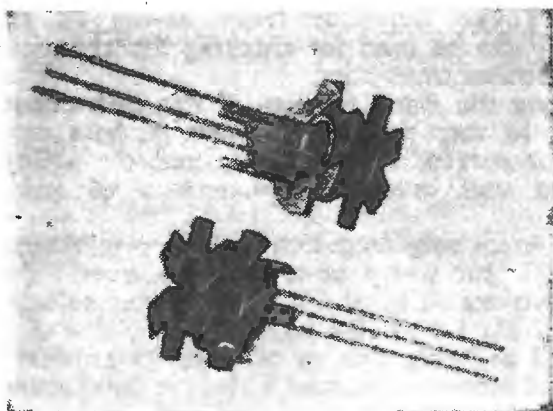

Casco transistor cooler.

0.1in-grid printed circuit board. It is claimed that using this cooler with transistors in JEDEC TO-5 cans allows their power handling capacity to be at least doubled (without exceeding the maximum allowable operating temperature). This cooler costs 4d and the auxiliary plate 3d. Another version of this cooler is available for JEDEC TO-18 cans and costs 4d. These coolers are distributed by SASCO Ltd., of Adastral House, Nutfield, Redhill, Surrey.

Miniature Amplifier

ALTHOUGH occupying less than one-tenth the volume of a matchbox, the new Sinclair Radionics miniature amplifier gives a power gain of 60dB. The frequency response is sensibly flat from 500c/s to 100kc/s, the

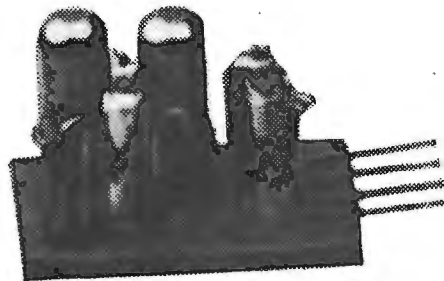

Sinclair Radionics miniature amplifier (without its case).

3dB points lying at 150cs and 200kc/s. The power gain is still 40dB at 2Mc/s. Any supply voltage between 1.5 and 9V may be used, the current drain correspondingly varying from 0.5 to 3mA. The maximum output voltage varies from 5V p-p for a 9V supply to 0.5V p-p for a 1.5V supply (output impedance $1k\Omega$). The input impedance varies from $10k\Omega$ for a 1.5V supply to $1k\Omega$ for a 4.5V (or higher) supply. A typical equivalent input noise voltage is $30\mu\text{V}$ (with infinite external impedance at the input.) This amplifier costs 28/6 in kit form or 38/6 ready built. It is available from Sinclair Radionics Ltd., of 69 Histon Road, Cambridge.

New Chopper Transistors

WHEN small direct voltages or currents, comparable with the drift at the input of a d.c. amplifier, are to be measured, a better technique is to short-circuit the input intermittently and to apply the resulting square wave to an a.c.-coupled amplifier. Typical applications are strain gauges, thermocouples and digital computers.

A new range of p-n-p silicon alloy chopper transistors has been developed by Brush Crystal with guaranteed offset current, $<0.05\mu\text{A}$ and typically $0.001\mu\text{A}$ at 25 volts (OC 742) and low offset volts, $<2\text{mV}$ and typically 1.3mV at 15 volts, (OC 740).

These two basic types are available from Brush Crystal Ltd., Hythe, Southampton, from whom full data sheets are available.

Industrial Indicators

A VERSATILE illuminated flush-mounted panel indicator (No. D870) has been introduced by Bulgin for applications where separate pilot lights and legend plates were previously required. The lamp box can be supplied with one, two or five light isolation barriers giving two, three or six legend areas on the translucent panel, which can be engraved to order. Either M.E.S. or M.B.C. lampholders can be supplied and the overall dimensions are $5\frac{1}{8}\text{in} \times 1\frac{1}{4}\text{in}$ with a back rejection of $2\frac{7}{16}\text{in}$.

Technical leaflet, reference 1505, is available from A. F. Bulgin & Co. Ltd., Bye Pass Road, Barking, Essex.

TRANSISTOR AMPLIFIER OUTPUT STAGES

2.—CASE FOR COMMON-EMITTER OPERATION: DRIVER STAGE PROBLEMS

By O. GREITER

THE previous article discussed the three forms of bridge structure which can be used for a push-pull output stage and showed that a single-ended stage could be regarded as a degenerate form of the bridge. It is now necessary to consider how the transistors should be used in the selected bridge. There are two main phases to this discussion. The first phase consists of what is really a reiteration of known facts, the statement of the reasons why common-emitter stages are used. The second phase is an examination of the ways in which transistors may be combined in order to reduce the distortion, simplify the drive or increase the power available.

Common-collector operation is a very tempting mode. It provides a low output impedance and because of the local negative feedback it is extremely linear. The input impedance is high. If we stop our assessment at this point we see a very favourable situation. However, a fully driven class B stage will demand a peak base-earth drive voltage which is approximately equal to the supply voltage. In theory a resistance-capacitance coupling from a driver stage operated from rather more than double the output stage supply voltage could be used. A quick consideration of the base bias network shows that this is not a practicable solution even if it were not so blatantly undesirable.

An interstage transformer must therefore be used. This transformer will conveniently have the ratio 1: (1+1) and can be wound to give very tight coupling between the three windings by the use of tripled wire. We now begin to see the high input impedance in rather another light, for the transformer must have a correspondingly high inductance. In what we may regard as the natural development of this form the driver will be a class A stage operating at a standing current rather above the peak base drive for the output stages. This may well be quite substantial so that the transformer will have to be relatively large, with an air gap, and there will be a problem about the resistance of the windings. The thermal stability of the output transistors will be seriously degraded if the total resistance in the base circuit is high, but the requirements for the common collector transformer lead inevitably to the highest resistance of any configuration.

A second problem which is often overlooked arises from the variability of the input impedance. The driver stage is of necessity a medium power stage. It is not just a voltage source, for although this is suggested in some texts we need only consider, for example, the 150mA drive needed by the OC26 to see that in a 12-volt system the driver will be dissipating at least 2 watts. The impedance which determines the response of the transformer is then, in approximate terms, the product βR_e for the out-

put transistor. The term R_e is virtually the load and may be considered to be constant. If the load is a loudspeaker of unknown characteristic in an unspecified box there are some additional problems. However, β is by no means constant, but varies substantially with instantaneous signal level. The transformer inductance of a particular transformer will also vary with the signal. The amplifier low-frequency response will therefore vary with instantaneous signal level. The term β varies from transistor to transistor, too. The overall effect is that we have a great deal of uncertainty, about the exact form of the amplifier characteristic and we must provide very large margins in our design to ensure stability when negative feedback is applied.

The case against the common collector circuit may have been over-stressed. R. F. Shea ("Transistor Audio Amplifiers," John Wiley, p. 182) shows

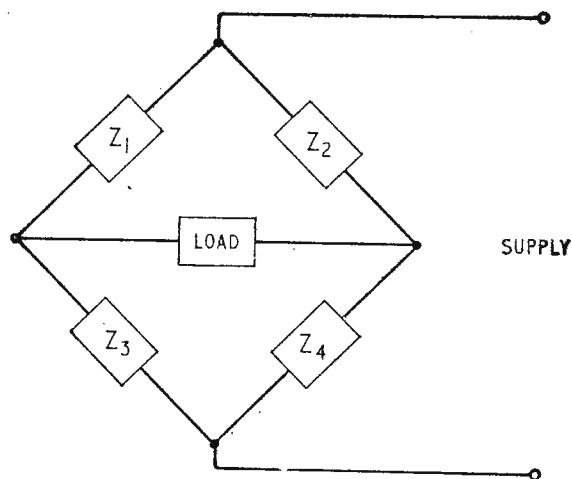

Fig. 4. Basic bridge circuit in which even terms cancel when $Z_1 = Z_2$ and $Z_3 = Z_4$.

how crossover distortion may be reduced with the common-collector circuit, but it is rather uncertain whether the reduction is greater than would be explained by the local negative feedback. This is rather important, for if the reduction is solely due to feedback it will be just as dependent on biasing as the crossover distortion in the other configurations. The inherently higher base resistance puts the system back into jeopardy and it can, in fact, turn out to be inferior to a system of higher thermal stability.

The common-base circuit also offers us the possibility of very linear operation, provided that we can drive it with a true current drive. However, this current drive demands a great deal of current and again we are forced to use a transformer. This transformer will give a voltage step-down from the

driver and it might appear that the fact that we are driving several amperes into the emitter against the emitter-base voltage, a fraction of a volt, would lead to very low inductance values. The inductance is determined, however, by the need to maintain current drive, for it is on this that the linearity depends.

It may be thought that the fact that the base is earthed will enable us to operate at higher voltages. The text-book analyses of thermal instability and of the avalanche breakdown mechanism will certainly give us this impression. When we turn to practical designs, however, we find that in order to bias the transistors to avoid crossover distortion we shall almost certainly wish to introduce the bias at the base rather than at the emitter. There seems to be no really convenient way of avoiding this. Immediately, then, we introduce resistance into the base lead and much of the advantage has gone.

The frequency response of the common-base connection is its strong point. It is well known that the response of the common-emitter stage begins to fall at a frequency which is nearly enough the alpha cut-off frequency, the common-base limit, divided by the current gain α' or β . There is some compensation here because of the additional gain of the common-emitter stage, for feedback may be used to sacrifice this extra gain and to obtain in return a wider bandwidth. Ideally it would appear that this should be a balanced transaction in which the common-base circuit would lose marks because of its lack of flexibility. Certainly we can say that conclusions based on approximate network equivalents should be suspect. Logically we might expect the power gain of the common-emitter stage to be β times that of the common-base stage, but in some references we find some disagreement here, usually because the argument is bedevilled by assumptions about source and load impedances.

K. W. Cattermole ("Transistor Circuits," Heywood & Co.) lists the comparative merits of the two types of stage, and provided that we accept that $\alpha \approx 1$ his conclusions are that the defects, distortion, constancy, bandwidth and temperature effects are all increased by the factor α' . The gain is also increased by the factor α' . He draws the conclusions that the common-emitter stage is only advantageous if it is good enough without feedback or if some property is particularly convenient. This is a very abbreviated statement of his position. Consider, however, a trans-

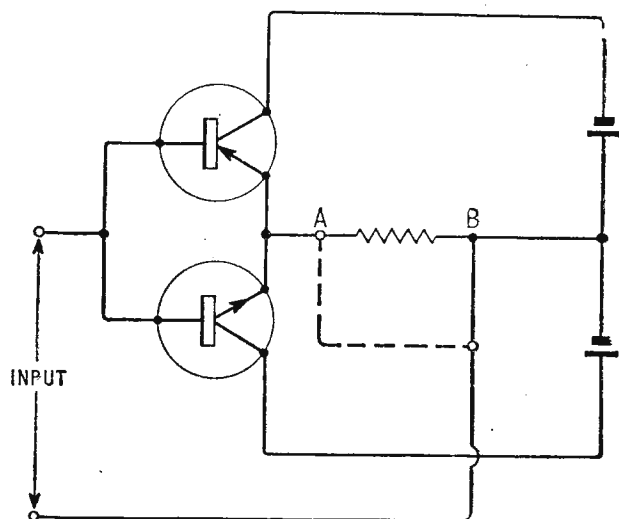

Fig. 5. Complementary pair with single-ended input.

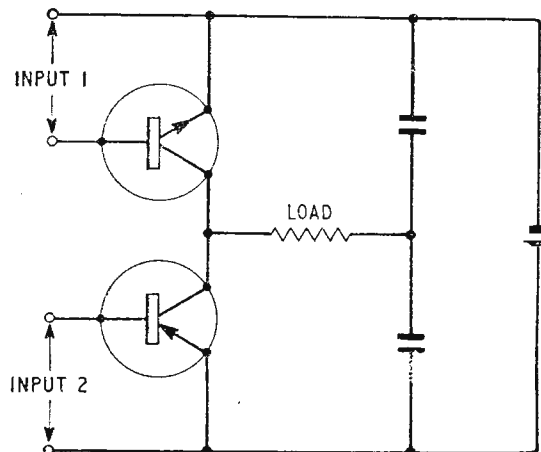

Fig. 6. Separate inputs overcome the drawbacks of the circuit of Fig. 5.

sistor having $\alpha' = 50$ and $f_{\alpha} = 250$ kc/s, so that $f_{\alpha}' = 5$ kc/s. A particular design can accommodate, let us say, a transistor cut-off frequency of 20kc/s. The common-base circuit is far too good, but the use of the appropriate amount of feedback will tailor a common-base circuit exactly to our requirements.

The advantage is that the available gain is brought into the working band and becomes available for use in overall feedback. It is well known that it is much more profitable to provide, say, 20dB of feedback round three stages than to distribute this 20dB as, say, 8 + 8 + 4dB among the stages themselves. The use of the common-emitter circuit gives us freedom. The reader may wonder why in the discussion, local feedback has been used at all, but here we encounter the problem of large single transient response. Feedback depends upon the signal travelling through the amplifier and then back to the input. Unless the first passage is reasonably undistorted the essential conditions are not satisfied and the simple theory of the use of feedback is not applicable.

So long as we are considering only simple transistor structures we may now assume that we shall be using common-emitter stages and in theory, though only to a rather limited extent in practice, there is a choice of various combinations of n-p-n and p-n-p transistors. In Fig. 4 (repeated from Fig. 1 of the previous section) we know that even terms will be balanced out so long as $Z_1 = Z_2$ and $Z_3 = Z_4$. In the most conventional, or at least traditional circuit, the one in which Z_1 and Z_2 are the centre-tapped windings of an output transformer and Z_3 and Z_4 are transistors we shall clearly use two transistors of the same type. It seems to be quite pointless to speculate on the meaning of circuits in which a complementary pair can be used, for the first circuits to come to mind has disadvantages which are typical of them all. There is nothing, then, in the circuit to make a choice between n-p-n and p-n-p and this decision will be made entirely on the basis of a study of the types available.

When Z_1 and Z_3 are transistors while Z_2 and Z_4 are capacitors the situation again favours the use of two transistors of the same type in order that we may easily ensure that the two halves of the waveform are treated equally. Any differences between the transistors must lead to the production of terms of even order. If this were the only consideration there would be no need to say any more. The basic simplicity of the driving arrangements in the circuit of Fig. 5, in which a p-n-p and an n-p-n transistor are used must commend it to us. Since the transis-

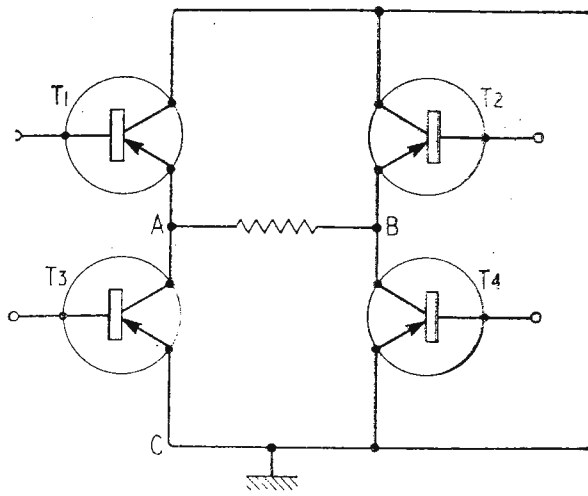

Fig. 7. Illustrating drive circuit limitations.

tors are complementary a positive signal at the input will cut off the p-n-p unit and drive up the n-p-n while a negative signal drives the p-n-p but not the n-p-n. This arrangement will eliminate the need for a push-pull input.

The difficulty arises when we have the lower side of the input returned along the dotted line to A so that the two transistors are operating in the common-emitter mode. The point B is the live end of the load and the whole battery will be driven up and down by the signal. It is not possible to use this battery for supplying any earlier part of the circuit. The result is, of course, the same if the centre-tap is derived by a capacitor circuit and it would be quite pointless to work out circuits using inductors to decouple the battery. It would be easier to use a transformer. The point B can be connected to the common input terminal, which is usually taken to be earth. The result of doing this is to set the two power transistors into the common-collector mode. It is, of course, possible to get round this difficulty by the use of an input transformer, but since the only real advantage of this form is that it can be driven by a single input a transformer, which could just as well drive a pair of similar transistors, is obviously not an answer which makes sense in the overall picture.

The practical solution of the problem is tied up with the driving circuit. There are many ways in which the two inputs needed for the arrangement shown in Fig. 6 can be achieved without the use of a transformer. These can be classed as drive circuits or they can be regarded as arrangements of compounded transistors. It would seem appropriate to delay any discussion of them until the more fundamental aspects have been cleared out of the way.

The full bridge circuit, as it is called, or the four-transistor version of the output bridge as it is more correctly described, requires that Z_1 and Z_2 should be matched, and that Z_3 and Z_4 should be matched. Ideally this is all and we can therefore use a variety of combinations. These turn out to be less simple than they look. Let us first consider the all p-n-p system shown in Fig. 7. The drive to transistors T3 and T4 can be applied to the bases and can have C as a common point. We shall have a quite conventional push-pull common-emitter mode of operation. T2 must be driven in phase with T3, while T1 is driven in phase with T4. If we attempt to use the same drive sources, with C as the common point, we must accept the fact that T1 and T2 are operating in the common-collector mode and they will require

the very large voltage drive associated with this mode. This means that two drive sources must be provided on each side.

Transformer coupling can be, and indeed is, used to enable T1 to be driven with respect to A while T2 is driven with respect to B, leaving a separate pair of windings commoned at C to drive T2 and T4. This is an arrangement of basic simplicity which suffers only from the defect that many designers wish to avoid the limitations of the transformers. The author is conscious of the fact that this attitude, though common, is not adopted by all designers and there are some who may feel that this stress on the question of transformer elimination is out of place. There is no doubt that more transformers are being used today than ever before with the result that deliveries of experimental transformers also take longer than ever before. Here is the root of the dislike for circuits with transformers.

The signal at B is, of course, in the right sense to act as a drive for transistor T3 so that if T4 is considered to be cut off while T2 is driven its conducting half-cycle as a common-collector stage we can use the emitter signal at B to feed the base of T3 through an appropriate value of resistance. Although this looks to be a plausible circuit when drawn in outline it looks a good deal less attractive as one approaches the problems more closely. The need to provide a small amount of forward bias and to control this forward bias by means of a temperature-sensitive device make the circuit look very much more uncertain as a solution. Indeed, most of the forms which look quite straightforward when drawn in their basic structures suffer from this disadvantage.

We must, of course, recognize that these basic structures exist. The most attractive of them all is probably the one shown in Fig. 8. So long as we close our eyes to the problem of biasing, this circuit has an admirable simplicity and symmetry as has the common-collector version of the circuit shown in Fig. 9. These circuits may well be found attractive for relatively low power amplifiers in which the impedances are correspondingly high. A transistor such as the OC84 requires about 3mA drive and about 300mV to produce this drive, so that the input impedance in grounded-emitter is in the 100 ohm region. This is very much more satisfactory for the planning of capacitance coupling than the 100mA base drive at 500mV, or 5ohms,

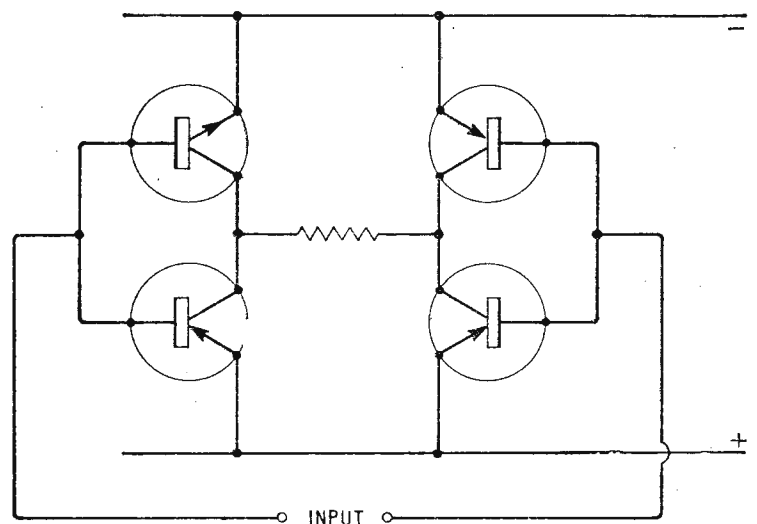

Fig. 8. Common-emitter drive circuit.

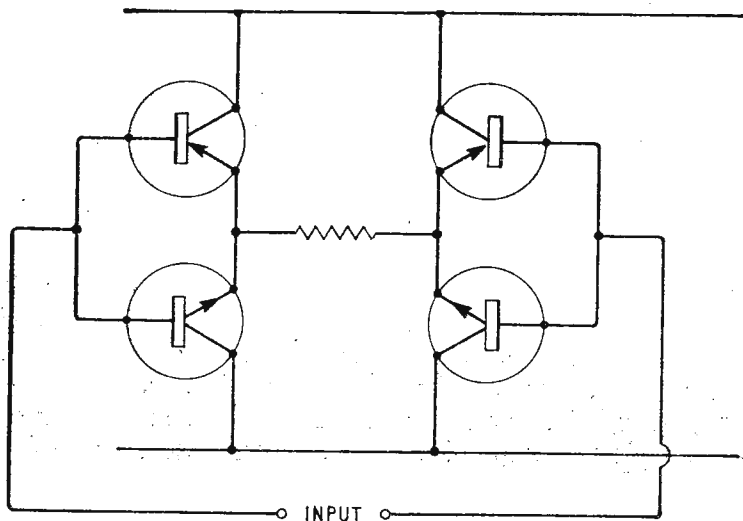

Fig. 9. Common-collector drive circuit.

input to the OC26. Whether in fact a designer would wish to use a four-transistor circuit to produce an amplifier of the 1,000mW class is uncertain. The designer who did wish to do so would probably be prepared to use a driving transformer so that he would be able to adopt a modified version, modified by doubling up the half-bridge, of the circuit given for a 500mW amplifier as Fig. 5, p. 172 of the "Mullard Reference Manual of Transistor Circuits."

In practice only the basic form of Fig. 7 seems to be used and it is common to find that the n-p-n/

p-n-p structure is used for driving this simple bridge. The theoretical attractions of the p-n-p/n-p-n power system vanish when we settle down to design in detail. The range of n-p-n transistors is limited, even in the North American market, and consequently the range of true complementary pairs is even more limited. Few designers will be prepared to provide an accurately balanced and well-screened transformer to couple the balanced output to the unbalanced feedback path and the other circuits, which will be discussed later, that are available do not provide a high attenuation to push-push signals. It must be noted that the attenuation called for here may be of the order of 50-60dB if no attempt is made at balancing the upper and lower arms of the bridge.

Much of this discussion is based on the properties of real transistors. If ideal transistors having a current gain of unity are used the circuits become much more practicable. The use of compound pairs in the Darlington configuration offers us what can be regarded as almost ideal transistors and makes the use of some of the forms we have been considering, and implicitly rejecting, a matter of common practice. New difficulties arise, not unnaturally, and it will be necessary to see just what these are. The backbone of power amplifier design remains the common-emitter stage and there are details in the design of common-emitter stages which require critical examination before we can proceed further. It is hoped that this topic can be discussed in the next issue.

Commercial Literature

"Sound" 4-track tape recorders will provide stereo playback when connected to the Sound Addon unit available as an optional extra at 14 gns. Descriptive literature of all the current Sound models is available from Tape Recorders (Electronics) Ltd., 784-788 High Road, Tottenham, London, N.17.

Morganite Resistors' latest publication "Morganite Qualification Approved Components," gives N.A.T.O. catalogue reference numbers to a wide range of variable resistors manufactured by the company. Morganite Resistors Ltd., Bede Trading Estate, Jarrow, Co. Durham.

Ampex literature newly available includes illustrated descriptions of the FL300 continuous-loop recorder/reproducer and the SP300 portable instrumentation recorder. Ampex Great Britain Ltd., 72 Berkeley Avenue, Reading, Berks.

RCA Receiving Tubes and Picture Tubes Booklet, now available in an enlarged edition, 1275K, contains a new tube classification chart, a tube application guide, and a revised characteristic chart giving data on more than a thousand RCA tubes. RCA Electron Tube Division, Harrison, New Jersey, U.S.A.

Jetlite headphones and headsets, manufactured by Amplivox Ltd., Beresford Avenue, Wembley, Middx., have applications in broadcasting, film monitoring, tape recording and general communications, and are fully described in a leaflet available from the company.

Plessey communications receiver Type PR152 is a compact all-transistor model covering the m.f. band (550-1500 kc/s) and the h.f. band (1.65-30 Mc/s) with a film-scale tuning system giving a total effective scale length of 18ft. Full specification details are given in publication 238 obtainable from Plessey's Telecommunications Division, Ilford, Essex.

Elliott portable d.c. test sets and reflecting dynamometer instruments are the subjects of two illustrated leaflets available from Elliott Brothers (London) Ltd., Century Works, Lewisham, London, S.E.13.

Q type relay contactors made by B. & R. Relays Ltd. are detailed in a new leaflet available from the company at Temple Fields, Harlow, Essex.

Specialized voltmeters produced by Dawe Instruments Ltd., Western Avenue, Acton, London, W.3, are the subject of two new leaflets. 611A deals with a d.c. valve voltmeter which facilitates measurements over the range 300 μ V to 1000V, and 616A describes a transistor millivoltmeter.

Varian potentiometer recorders, marketed in the U.K. by Livingston Laboratories Ltd., 31 Camden Road, London, N.W.1, now include a G14 transistorized instrument using 6 $\frac{1}{2}$ " in wide charts and having spans of 1, 10, 100 mV and 1V with a pen speed of 0.6 sec. for full scale. An illustrated leaflet describes Varian potentiometric instruments.

Mullard have produced a quick reference chart to their special quality valves and equivalents; copies from the company's Government and Industrial Valve Division, Mullard House, Torrington Place, London, W.C.1. The component Division has produced a 15-page illustrated booklet entitled "Mullard Microcircuits."

"Terminology," an illustrated publication by Sealectro Corporation, Hershaw Factory Estate, Walton-on-Thames, Surrey, details in its sixth issue, Sealectro sockets for retaining semiconductor devices.

Daystrom Squaretrim sub-miniature trimming potentiometers are specified in a data sheet available from the company at Daystrom Incorporated, Potentiometer Division, Archbold, Pennsylvania, U.S.A.

What is an Electric Current?

By "CATHODE RAY"

THE most difficult things to define are the elementary ones. This is because there may not be any terms still more elementary with which to define them. If you were to gather together a quantity of learned Professors of Electrical Engineering and put to them some very difficult-sounding questions you would no doubt get unanimous and satisfactory answers, all in a spirit of sweet reasonableness. But ask them about something elementary, such as the cause of induced voltages, and in next to no time they'll be heatedly contradicting and perhaps even insulting one another.

Directly you saw my title question you may have guessed that the catch was what is meant by electricity. If so, you were wrong. I am taking that for granted. Then, you may say, surely there is no difficulty? Electric currents are movements of electric charges. Haven't I said so myself, as recently as two months ago?

In circuits such as Fig. 1—or even vastly more complicated ones such as an automatic telephone exchange—that may be fair enough. One can imagine a sub-microscopic road census clerk stationed at some point along the wire, counting the electrons (tiny negative charges) as they pass by in the opposite direction to the current arrow. For every 6,240,000,000,000,000 of them counted per second he would reckon 1 amp. Even if he wanted to do it the hard way and stationed himself in the acid between two plates of the battery, the principle would still be the same, but of course it would be

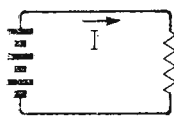

Fig. 1. Very simple electric circuit, in which the rule that the amount of current is the same all the way round is true.

more complicated in practice because he would have to count negative ions going one way and positive ions the other and add them together.

Fig. 2 looks simple enough too, and so long as the clerk chose a point corresponding to any of those available in Fig. 1 he would be in a position to give a correct figure. But if he was an awkward cuss and took up his position between the plates of the capacitor he would, in accordance with the usual definition of an electric current, invariably declare a nil return, even just after switching on. This would be in flat contradiction to the results sent in by an inspector deputed to investigate by making an independent check elsewhere in the circuit. Anybody who offered the bright suggestion that the current might have come to a stop somewhere along the circuit would be promptly squashed by reference to Kirchhoff's current law, which says that all the current arriving at any point must also be leaving it.

A less extreme discrepancy, but nevertheless a discrepancy, would arise with circuits such as Fig.

3, so long as the voltage across the capacitor was changing, which it would do for some time after switching on. The current through R_2 would not be the same as that through R_1 , and there would be none between the plates of the capacitor. Yet no question would arise if the clerk observed the capacitor current in the wires leading to it.

Clerk Maxwell—that was his name, not his occupation—saw this difficulty and dodged it by imagining a different sort of current in the empty space

Fig. 2. In this simple circuit, although current certainly flows nearly all the way round, at least for a time after connecting the battery, no movement of electric charges can be detected between the plates.

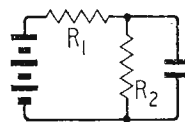
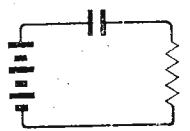

Fig. 3. Here is a circuit where, although no charges move across the space between the plates, the current through R_2 is not always the same as through R_1 .

between the plates. He called it displacement current. The reason for this name was that in the theory of electrostatics there already existed a quantity called displacement, to which Maxwell's supposed current was directly related. In case you have forgotten (or never knew) about this, let us recapitulate.

Very early in the history of electricity it was discovered that an insulated conductor could be charged; that is to say, made to have those peculiar properties called electrical, such as attracting pith balls, separating gold leaves and (if charged intensely enough) producing sparks. Much later, when the people who investigated these matters got around to measuring them and their causes, they found that the amount of the charge was directly proportional to the voltage used to impart it, and also depended on the dimensions of the charged conductor and its distance from its conducting surroundings (assumed to be at zero voltage) and on the kind of insulating material in between. Broadly speaking it was directly proportional to the area of the charged surface and inversely proportional to

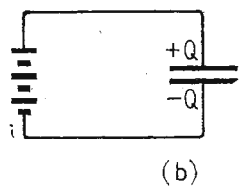
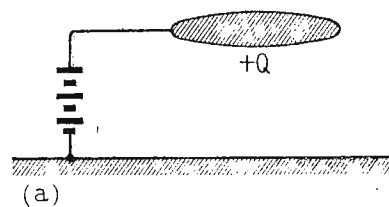

Fig. 4. (a) Diagram of "charging a body" in the old electrostatic experiments. This is essentially the same as charging a modern capacitor (b).

the distance of separation, but these quantities had no simple meaning unless they were uniform all the way, as when the charged body and its "surroundings" consisted of equal parallel plates close together—or were related in some other simple way, as with coaxial cylinders.*

For convenience, all the charge-determining factors other than the voltage were lumped together as "capacitance" (in those days, "capacity"). In the simple arrangements just mentioned, the capacitance can be computed from the dimensions and the known multiplying effect of the material between (relative permittivity, or dielectric constant) but in general it is easier to measure the charge Q transferred by an applied voltage V and get at the capacitance C from the equation

$$Q = VC$$

which, as we have just recalled, sums up the results of much experimenting. Of course, the units used in the equation have to belong to an approved system, or some constant coefficient would be needed to relate them. Coulombs of charge, volts

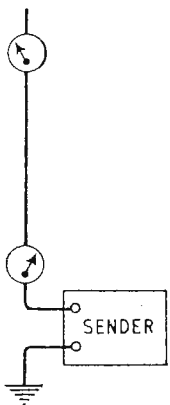

Fig. 5. The current indicated near the top of a sending aerial is much less than lower down. Is this a breach of Kirchoff's current law?

and farads are members of the usual approved system.

We see that if the voltage is constant the charge is constant; therefore there is none moving in or out; therefore there is no electric current. But if the voltage across the capacitance is varying, the charge is varying in proportion, so there must be a current in the wire connecting the source of voltage to the capacitance, proportional to the rate at which the voltage is varying. In mathematical symbols:

$$I = C \frac{dV}{dt}$$

This is how a capacitive path differs fundamentally from a conducting path, in which the current is proportional to the conductance ($G, =1/R$) and to the voltage, as stated in a slightly modified form of what is commonly known as Ohm's law:

$$I = GV$$

Although capacitance exists between *any* conductors capable of being at different electrical potentials

* Beginners sometimes have difficulty in seeing that charging a present-day capacitor is the same sort of thing as charging a "body" in the old electrostatic experiments, so in Fig. 4 I show them side by side. It is now known that when the + pole of the battery is connected to the "body" it attracts electrons away from the body (leaving an excess of positive charge) and transfers them (or an equal number) to whatever is in contact with the - pole—in Fig. 4(a), earth. Since earth is conventionally regarded as being at zero potential, the presence of this equal negative charge is often ignored. But it must be there. In Fig. 4(b) it is indicated as $-Q$. For reasons which became clear when the part played by electrons in atoms was discovered, the creation of a charge of one sign necessarily creates an equal charge of the opposite sign.

—for example, the leads of a resistor—it will make things easier to consider parallel plates close enough together for all external capacitance to be neglected. And to exclude another complication let us assume a vacuum between them.

Although I said that capacitance depends on the dimensions of the conductors, these are only significant in so far as they are the dimensions of the space between the conductors. For instance, making the plates thicker alters their size without necessarily altering the size of the space, so has no effect on the capacitance. It is quite essential to realize that capacitance is a property of the space, not of the conductors. They are needed only to specify the space and enable the charges to move.

How empty space can *do* things, such as transmitting waves and storing energy, is one of the great mysteries. It is so inconceivable that for a time a thing called æther was imagined to exist everywhere, solely to account for these effects. But all attempts to demonstrate its existence having failed, most authorities have abandoned it and simply accept the experimental facts, relying on mathematical statements of them rather than working models that can be pictured in the mind.

This is all very well for the more penetrating minds, but it makes things difficult for plodding students like ourselves. However, most of us do get some comfort out of describing the state of the space between the plates of a charged capacitor as "an electric field." If that is still too vague because it can't be shown in a diagram, we imagine "lines of force." They are all right so long as we realize they have no actual existence, being only a conventional means of representing the intensity and direction of a state that exists throughout the space, in the same way that lines might be drawn to indicate water flowing through a pipe—streamlines, in the strict sense.

Now the strength of an electric field is reckoned in volts per metre (in the m.k.s. system) and denoted by E (not to be confused with E denoting an e.m.f.). So the closer together the plates of a capacitor, charged to a given voltage, the stronger the field between them. According to the lines-of-force convention, each line is supposed to start with a unit of positive charge and end with a unit of negative charge. This could only be, of course, if there were equal numbers of each, as we noted in connection with Fig. 4. And the greater number of lines needed to represent the field between plates closer together is in agreement with the fact that the greater capacitance means a large number of units of charge on the plates, for lines to join.

Now let us fill the space between the plates with some kind of insulating material or dielectric. We know that this increases the capacitance; why it does so is another story which we won't bother about just now. Therefore, if we still maintain the same voltage, the number of units of charge on the plates increases. So there are more lines. Yet the distance between the plates is as before and therefore the field strength is unchanged. So there are no more lines.

This contradiction is because we are using lines for two different things. We started by using them as lines of *force*, to represent electric field strength. This field causes what is called electric induction or flux, which can also be shown as lines. It is these that begin and end on charges. All this is

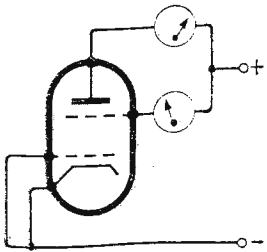

Fig. 6. There is no e.m.f. between second grid and anode of a tetrode connected like this (as in many output stages). Yet current flows from one to the other. What about Ohm's law?

analogous to lines of magnetic force and lines of magnetic flux; in iron, the latter are far more numerous. And just as we have magnetic flux density (lines per square metre) there is electric flux density. But it is usually called *displacement* and denoted by *D*. The name presumably arose from a mental picture of the displacement of an elastic barrier when a force or pressure is applied to it. But there is no reason to suppose that anything actually is displaced between the plates of a capacitor when it is charged. It just happens that the relationship between *E* and *D* is the same as if there were. That is to say, constant *E* causes constant *D*; for motion (varying displacement) it is necessary to vary *E*. This is also what is necessary for a current in the leads to a capacitor, so Maxwell bridged the gap between the plates with what he called displacement current, proportional to the rate of change of *D*, which is written dD/dt . Since *D* is electric flux density, one has to multiply by the area of the plates, *A*, to get the rate at which the whole electric flux changes.

Then, in a suitable system of units (such as m.k.s.),

$$I_d = A \frac{dD}{dt}$$

where I_d is the displacement current.

You may be wondering why Maxwell was so concerned about describing what goes on between the plates of a capacitor as a current, when such a very great stretch of the imagination is needed. Clearly, you may say, it is not a current within any reasonable meaning of that word, so why try to make out that it is?

One reason is that as the frequency is raised Kirchhoff's current law† becomes more and more untrue, if "current" includes only what our traffic census would reveal. An ammeter (of a type suitable for accurately reading h.f. current) gives quite different readings in an aerial wire, depending on where it is inserted. (Fig. 5). That is because of the distributed capacitance of the wire. It is nice to have a meaning of current that makes Kirchhoff true even in such circumstances.

But there are yet more important electrical laws that can only be saved in this way. We all know that every current sets up a magnetic field—most of electrical engineering depends on that fact. And we, as readers of *Wireless World*, should know that a magnetic field is also set up in space where an electrical field is varying; that is to say, where Maxwell's "displacement current" exists. All of radio engineering depends on that fact. It was through considering fields mathematically that Maxwell arrived at his famous equations which led to the conclusion that electromagnetic (or radio) waves existed, and that they would travel through empty

† Although Kirchhoff's laws may be first brought to our notice in connection with resistive circuits, they are perfectly general and provide the basis for a.c. network calculations.

space with the speed of light. But in order to do so it was necessary to take a wider view of what an electric current is, including dD/dt as well as dQ/dt .

So much for that. But even currents consisting of moving charges are not all the same kind. Probably in Lesson 1 of electricity we learned that an electric current is caused to flow by an e.m.f.; and that was the cue for Ohm's law, whereby we made the acquaintance of resistance, which determines how much current a given e.m.f. will cause. Always some e.m.f. was needed—until a year or two later, when we heard of superconductivity. But nobody really understands that, and anyway it only happens within a few degrees of the absolute zero of temperature, so is fortunately far beyond the experience of all except a few research physicists. So are you surprised to know that right in your home you have current flowing freely without e.m.f.? That is, if it is reasonable to assume that your home is not without a multi-electrode valve or cathode-ray tube.

For whereas (superconductivity apart) an e.m.f. is needed to keep electrons flowing steadily through even the thickest copper wire, nothing is needed to keep them flowing all on their own through a vacuum. It is true that quite a high voltage (it is called "h.t.") is needed to get them across to the anodes of valves, and very much higher voltage (e.h.t.) to do the same in c.r. tubes. But if you try the experiment indicated in Fig. 6 you will find a substantial current in the anode circuit, although no e.m.f. or electric field exists to carry it across the space between second grid and anode. There is hardly any need actually to set up such an experiment; it is probably going on already in the output stage of your receiver. The fundamental difference between this current consisting of electrons travelling on their own through a vacuum and electrons travelling through a conductor is shown by observing the result in the conduction equivalent (Fig. 7); in both circuits the resistances of the meters are supposed to be negligible. So although we often think of valves as having internal resistance (r_a) this is less truly resistance than displacement current is current.

Of the two kinds of "real" current, the sort that flows in wires is called conduction, or, in plainer

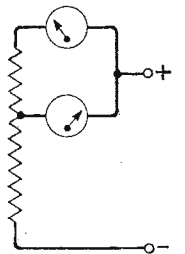

Fig. 7. Repeating the experiment with a conductor gives quite a different result.

English, led current. The sort that has no conductor is called convection or carried current. The flow of electrons in vacuum tubes is the most familiar example, but even if charges are mechanically carried from one place to another they prove themselves to be truly an electric current by causing a magnetic field. Someone of the name of Rowland actually demonstrated this by spacing a number of conducting areas around the rim of an insulating disk, charging them, and rotating the disk. The resulting magnetic field—which reversed with direction of rotation, and increased with speed of rotation—was detected by a magnetized needle.

I'll sum up by comparing the response of all three

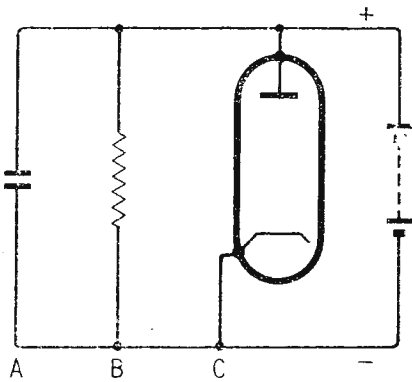

Fig. 8. Currents in these three paths, A, B, and C, respond in three different ways to an e.m.f.

kinds of current to a steady e.m.f. In Fig. 8 the appropriate types of path are connected in parallel to such an e.m.f., which sets up a uniform constant difference of potential between the upper and lower rails.

The result, so far as path A is concerned, is a constant electrical displacement, and because displacement current is equal to rate of change of displacement it is nil here.

In the conduction path, shown as a resistor, electrons drift upwards at a constant rate. In a metal conductor this rate is very slow (unlikely to be more than a fraction of an inch per second) but because there are enormous numbers of electrons in metals

the census clerk would still have a job counting them going by

In the vacuum tube the electrons accelerate at a steady rate all the way up. But their resulting thinning out towards the top offsets their increased speed, so the current is the same everywhere along the tube, just as exactly the same number of cars pass per second, on the average, along a fast straight in a motor race as on a hairpin bend where many more may actually be within visual distance.

If for simplicity we assume a uniform electric field strength throughout the length of the tube, then the electrons in it are subject to uniform acceleration. With a given number of starters, the current is inversely proportional to the time taken for the journey, and calculation shows the reciprocal of time to be proportional to the square root of the rate of acceleration, which is proportional to the field strength, and over a fixed distance that is proportional to the voltage applied. In brief, then, the current through the tube is proportional to \sqrt{V} , whereas in a conductor subject to Ohm's law (such as path B) it is proportional to V . Convection currents therefore do not obey Ohm's law, and if we do assign their paths a figure of resistance this resistance is non-linear—it depends on the voltage applied or the amount of current flowing.

Is all this perfectly familiar? It certainly ought to be, for Fig. 8, containing the natural routes of all three different kinds of electric current, is typical of even the simplest electronic circuits.

FEBRUARY MEETINGS

Tickets are required for some meetings; readers are advised, therefore, to communicate with the secretary of the society concerned.

LONDON

6th. British Kinematograph Society.—“Film and world television” by Richard Cawston at 7.30 at Central Office of Information, Hercules Road, S.E.1.

7th. Television Society.—“Education by television” by K. Fawdry at 7.0 at the Cinematograph Exhibitors' Association, 164 Shaftesbury Avenue, W.C.2.

8th. I.E.E. & Brit.I.R.E.—Discussion on “Physical methods of gas analysis” at 6.0 at Savoy Place, W.C.2.

11th. I.E.E.—“Ionospheric sounding by incoherent scatter at very-high frequencies” by E. D. R. Shearman at 5.30 at Savoy Place, W.C.2.

14th. I.E.E.—Faraday Lecture on “Electronics—the key to air safety” by Dr. E. Eastwood at 6.0 at the Central Hall, Westminster, S.W.1.

14th. Radar & Electronics Assoc.—“Television outside broadcasts” by L. F. Mathews and S. Wade at 7.0 at the Royal Society of Arts, John Adam Street, W.C.2.

15th. Institute of Navigation.—“Why ships collide” discussion led by Capt. F. J. Wylie and Capt. J. P. Stewart at 5.30 at the Royal Institution of Naval Architects, 10 Upper Belgrave Street, S.W.1.

15th. B.S.R.A.—“Transistor audio power amplifiers” by R. C. Bowes at

7.15 at the Royal Society of Arts, John Adam Street, W.C.2.

20th. I.E.E.—“Transmission problems on bands IV and V” by H. Page at 5.30 at Savoy Place, W.C.2.

20th. Brit.I.R.E.—“Electronics in nuclear power” by S. Young at 6.0 at the London School of Hygiene and Tropical Medicine, Keppel Street, W.C.1.

21st. I.E.E.—Discussion on “Ferromagnetic films” opened by C. E. Fuller at 5.30 at Savoy Place, W.C.2.

21st. Television Society.—“Television relaying by artificial earth satellites” by W. J. Bray at 7.0 at the Cinematograph Exhibitors' Association, 164 Shaftesbury Avenue, W.C.2.

BEDFORD

26th. Instn. of Prod. Engrs.—“The friendly electron and the unfriendly missile” by I. A. Cuthill at 7.30 at the Dujon Restaurant, High Street.

BOLTON

7th. Brit.I.R.E.—“Transistor switching and logical element circuitry” by M. W. Gribble at 7.0 at Bolton Technical College.

BRIGG

18th. I.E.E.—“Electronic data processing” by C. W. Mortby at 7.0 at the Angel Hotel.

BRISTOL

12th. Television Society.—“Space communications system” by J. K. S. Jowett at 7.30 at Royal Hotel, College Green.

20th. Brit.I.R.E. & R.Ae.S.—“Communications satellites” by L. H. Bedford at 7.0 at the University Engineering Lecture Rooms, Queens Buildings, University Walk.

BRIGHTON

20th. Instn. of Prod. Engrs.—“Tape control of machine tools” by J. R. Thompson at 7.0 at the King & Queen Hotel, Marlborough Place.

CARDIFF

6th. Brit.I.R.E.—“Space research” by G. Ratcliffe at 6.30 at the Welsh College of Advanced Technology.

DONCASTER

27th. I.E.E.—“Some problems in the manufacture and design of fractional horsepower motors” by F. L. Fletcher at 7.0 at the College of Technology, Waterdale.

DUBLIN

21st. I.E.E.—“Semiconductor static switching” by D. D. Jones at 6.0 at the Physical Laboratory Extension, Trinity College.

EDINBURGH

6th. Brit.I.R.E.—“Some recent aids to electronic production” by M. Richards and D. G. Hall at 7.0 at the Department of Natural Philosophy, The University, Drummond Street.

12th. I.E.E.—“Oscillation in feedback systems with periodic interference” by Z. J. Jelonek at 7.0 at the Carlton Hotel, North Bridge.

FARNBOROUGH

21st. Brit.I.R.E.—“Integrated semiconductor circuits” by Dr. J. T. Kendall at 7.0 at Farnborough Technical College.

GLASGOW

7th. Brit.I.R.E.—“Some recent aids to electronic production” by M. Richards and D. G. Hall at 7.0 at the Institution of Engineers and Shipbuilders, 39 Elmbank Crescent.

11th. I.E.E.—“Oscillation in feedback systems with periodic interference” by Z. J. Jelonek at 7.0 at the Royal College of Science & Technology.

22nd. Society of Instrument Technology.—“Principles of computers” at 7.15 at the Scottish Building Centre, 425 Sauchiehall Street.

LEEDS

19th. I.E.E.—“Direct current; its uses and its conversion” by J. E. Boul at 6.30 at the Leeds & County Conservative Club, South Parade.

LEICESTER

19th. Television Society.—“Propagation and aerials for bands IV and V” by C. F. Whitbread at 7.30 at The New Vaughan College, St. Nicholas Street.

LIVERPOOL

20th. Brit.I.R.E. — “Microwave valves” by C. R. Russell and K. T. W. Milne at 7.30 at the Walker Art Gallery.

LOUGHBOROUGH

25th. Brit.I.R.E. — “Productivity through electronics” by J. A. Stokes at 7.0 at Loughborough College of Technology.

MANCHESTER

27th. I.E.E. & Instn. of Production Engrs.—“Electronic control of machine tools for production” by Dr. E. H. Frost-Smith at 7.15 at Reynolds Hall, College of Science & Technology, Sackville Street.

MORECAMBE

20th. Society of Instrument Technology.—“Solid state instruments for process control” by I. C. Hutcheon at 7.15 at the Imperial Hotel, Regent Road.

NEWCASTLE-ON-TYNE

4th. I.E.E.—“Optical masers” by I. L. Davies at 6.30 at Rutherford College of Technology, Ellison Place.

18th. I.E.E.—“Data processing” by R. H. Tizard at 6.30 at Rutherford College of Technology, Ellison Place.

OXFORD

13th. I.E.E.—“Contactless switching of the future” by D. D. Jones at 7.0 at the Demonstration Room, Southern Electricity Board, 37 George Street.

PORTSMOUTH

27th. Brit.I.R.E.—“The specification of iron-cored transformers and reactors for use in electronic circuits” by T. P. Lynott and D. M. Fidler at 7.0 at Portsmouth College of Technology.

RUNCORN

11th. I.E.E.—“The training of instrument engineers” by Prof. J. E. Parton at 6.30 at I.C.I., The Heath.

WIRELESS WORLD, FEBRUARY 1963



NEW SIGNAL LAMPS

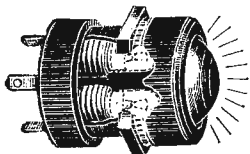

List No. D.855-856

D.855-856

Where lamp failure would be dangerous or costly this double-supervision Signal Lamp holder should be used. Containing two L.E.S. lamp-sockets, which should be wired in parallel, each lamp supervises the other, and whilst lamp failure is apparent (by slight dimming of light) the signal is not lost.

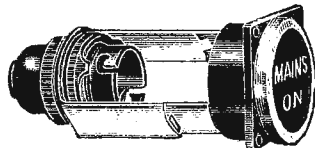

List No. D.828

D.828

A mains Signal Lamp with open bracket construction, allowing maximum heat dissipation, and panel window which is able to take legends. Legends can be supplied in any language and colour, either secret-until-lit or always visible, normally supplied secret-until-lit.

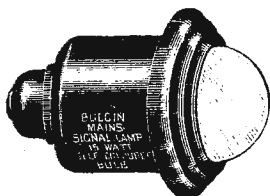

List No. D.653

D.653

A Lens-less mains Signal Lamp for use with 15W. Mazda (and similar) coloured lamps. The lamp which is globular, half projects from the bezel and thus becomes its own lens. A clean, efficient appearance results whilst the lit performance is exceptionally brilliant.

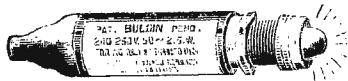

List No. D.880-881

D.880-881

A unique Bulgin Development (**Patent Applied for**) offers a *mains* Signal Lampholder, for all types of equipment, which has a number of desirable “*low voltage*” features. Comparatively robust and small 50V., 50mA., 2½W. filament lamps are used but the rear terminals take FULL Mains Voltage (50 c/s only), other c/s can be supplied to order.

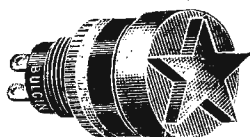

List No. D. 675/2-/6

D.675/2-/6

A range of Signal Lamps which employ the use of symbols instead of legends for identification. There is a choice of five symbols, Star (*as illustration*), Roundel, Triangle, Hexagon and Maltese Cross, and five translucent colours, Red, Yellow, Green, Blue and White, from which to choose. When illuminated the symbol shows in silhouette on a coloured background.

FOR DETAILS OF OUR FULL RANGE, SEND FOR LEAFLET REF. No. 1502/C.

A. F. BULGIN & CO. LTD.

BYE-PASS ROAD, BARKING, ESSEX.
Telephone: RIPLEWAY 5588 (12 lines).



By "FREE GRID"

Why Hams?

YOU have so often helped me when I have been trying to dispel my crass ignorance about something that I appeal to you once again. I do it with some trepidation because it is something which probably every reader of *W.W.* except myself knows.

I want to know why it is that a wireless amateur, more especially a transmitter, is known as a "ham." Books of reference do not help me much. In any case, I mistrust them since the day one of them told me that the word "phoney," as in "phoney war," was an American expression, whereas it is a Yankee corruption of the Erse word "Fainne" (meaning "fake" or "pretended") which the Irish took to the U.S.A.

I have, in my ignorance, usually supposed that originally wireless amateurs were called "ams" for short and that somehow the "h" became tacked on. I feel, however, that there is some more subtle explanation. All of us who have at any time listened to incoming morse (no matter whether it be transmitted by an amateur or professional) have now and again come across a ham-handed Henry who sounds as if he were using his clenched fist instead of his fingers and thumb as advocated by H. F. Smith in his book "Learning Morse."

Indeed, some key manglers sound as though they were using a less delicate anatomical instrument than their clenched fist, namely one of their hams which I understand to be a part of the leg structure of both sexes. At any rate I have, in my time, heard a sender sometimes implored not to use his foot.

But I feel this is not the correct explanation, for it is my experience that most amateur transmitters are as expert at handling their type of keys as Paderewski was at handling his. I think a clue may be found in the superlative expression "dyed-in-the-wool ham." The O.E.D. tells me that cloth, when dyed-in-the-wool before spinning, represents what is best in the dyer's world, and so the expression, when used figuratively, means the best possible.

Thus a "dyed-in-the-wool ham" means the type of ham who is utterly devoted to his pursuit, and we at once realize that "ham" must be the monosyllabic abbreviation of hamadryad, the wood-nymph of Greek mythology who was so utterly devoted to the tree in which she was

born that she remained with it until it died.

Surely such utter devotion to one thing is truly descriptive of a wireless ham? I know a hamadryad was a female, but are there not plenty of devoted YLs in amateur ranks?

I am very anxious to be corrected if I am wrong, and, of course, to know the real origin of the word.

One-Man Trams

AT the time of the heavy fog last December, several newspapers dropped hints that the Road Research Laboratory at Crowthorne, Berkshire, had something on the stocks which would eventually enable us to steer our cars through the encircling gloom by electronic means.

Naturally I made a few enquiries, and it appears all to boil down to a.c.-carrying cables buried under the roadway which a driver, or a robot driver, in the car could easily follow. There is nothing very startling in this because everyone knows that it would be easy for even a pedestrian, armed with a search coil at the end of a walking stick, to pick up the a.c. signal and convey it to headphones. It is as easy as that and older than radio for it is merely a question of induction. Naturally it could be elaborated so that instead of signals in headphones, the car could be equipped with a c.r.t. showing the line to follow. It could also be equipped with servomechanism to actuate the steering gear.

To adopt a system of this nature would simply be to destroy the freedom of the open road, and convert the car into a one-man tram. In fact it would save a lot of complication if, instead of the buried cables, tram lines were laid and each car fitted with flanged wheels. After all, a tram, whatever its disadvantages, can at least find its way home through fog.

What is wanted, of course, is some self-contained apparatus in the car without the necessity of buried a.c. carrying cables. Naturally radar suggests itself, but this would necessitate each car being fitted with a large trailer to carry the apparatus.

Frankly I can see no easy or inexpensive solution to the problem. A horse is still the most reliable means of locomotion in a fog, as it will always find its way home even if the rider or driver is asleep. It does this even without employing acoustic radar as does a flittermouse.

Slipped Discs

IT is astonishing how much the painful malady popularly known as "slipped disc" has come to the fore in the past three decades or so. To my mind the cause can be laid squarely at the doors of the electrical and radio industries.

All of us who are in any way connected with the technical aspects of electrical engineering must take our share of blame for the extra load we have thrown on to the already heavily burdened backs of doctors and surgeons. We ought, therefore, to do our best to relieve this pressure on them, as we most certainly can.

The chief cause of the trouble is the growing use of electric fires and TV sets; sound radio receivers, owing to the growing popularity of self-contained transistor sets, are becoming less and less culpable. Fires and TV sets are usually connected to the mains by a length of flex running to a wall socket a few inches above the floor. This means that every time one of these devices is switched on or off we have to bend down in a disc-slipping posture.

It is useless for opponents of my theory to point out that nearly all radio sets, no matter whether TV or sound, have a combined switch and volume control, and that they are nearly always switched on and off by this device, instead of by the switch on the skirting board.

Anybody with any experience at all with the use of a radio set of any kind learns to avoid using this volume control switch. Its use means that every time it is desired to switch off, the arm of the volume control has to travel in a wide sweep over its track before it triggers the switch. If this is done several times a day the track eventually becomes unnecessarily worn and therefore noisy. For this reason people apparently prefer to risk slipping a disc to quickly wearing out their volume control.

Now obviously we could not have our switch-plug mounted at the same level as our lighting switches, because people would be continually tripping over the flex. But there seems no reason at all why the switch and the socket of the usual switch-plug should not be in two parts, the socket remaining on the skirting board, and the switch at a more convenient level. I can see no snags in this idea at all. Can you?